

1. General Description

The WR0332-AT is a high accuracy, low noise, high speed, low dropout, CMOS linear regulator with high PSRR. The WR0332-AT can source 300mA of output current with an input voltage range of 2.2V to 5.5V and an output range of 1.0V to 3.3V, making the device can be used for a wide variety of applications. Low-dropout voltage and low quiescent current make this series of devices ideal for a wide range of battery powered devices. The WR0332-AT has the fold-back maximum output current which depends on the output voltage. So the current limit functions both as a short circuit protection and as an output current limiter. All device versions have thermal shutdown and current limit for safety.

These features of the device make it ideal for use in automotive equipment, offering a new cost-effective alternative for in-vehicle equipment.

The WR0332-AT regulator is available in a standard SOT23-5 package. The standard product is lead-free and halogen-free.

2. Features

- PSRR : 70dB@1kHz
- Output Current: 300mA
- Input Voltage: 2.2V~5.5V
- Output Voltage: 1.0V~3.3V
- Dropout Voltage: 220mV @ $V_{OUT}=3.3V$
- Quiescent Current: 60 μ A (Typical)
- Shut-down Current: < 1 μ A
- Recommend Capacitor: 1 μ F
- AEC-Q100 qualified for automotive applications:
Ambient temperature grade 1: - 40°C to 125°C

3. Applications

- Automotive infotainment
- ADAS cameras and radar
- Navigation systems
- Telematics systems

4. Typical Application

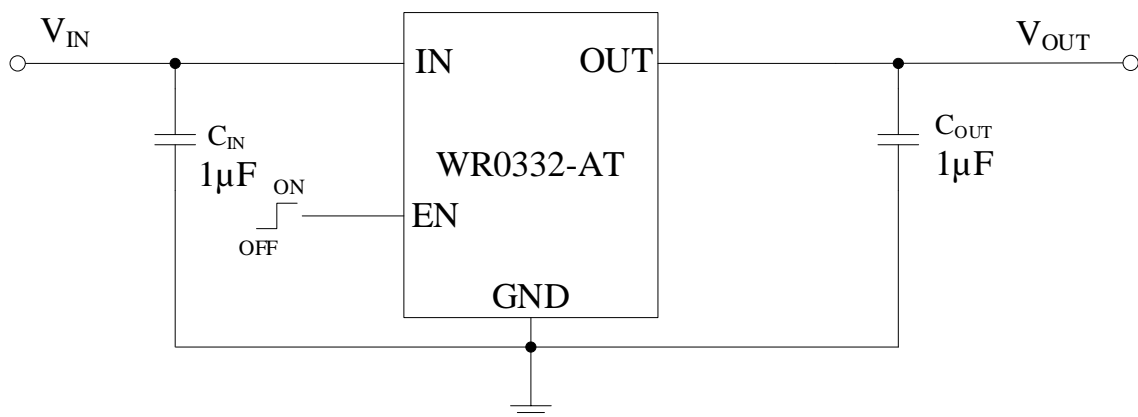

5. Pin Configuration

(Top View)

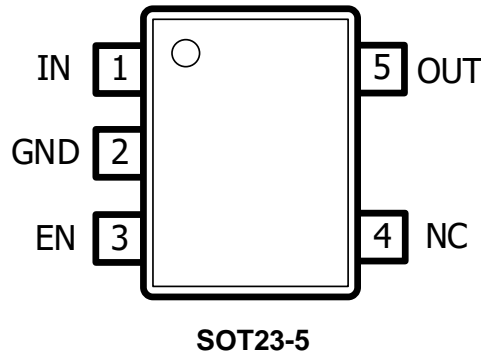

6. Pin Description

PIN NUMBER	PIN NAME	I/O	PIN FUNCTION
1	IN	I	Input voltage supply. Bypass with a typical 1 μ F capacitor to GND. Place the input capacitor as close to the IN and GND pins of the device as possible.
2	GND	-	Common ground.
3	EN	I	Enable input. Active High. EN includes a small pull-up current source, nominally 0.1 μ A.
4	NC	-	NC.
5	OUT	O	Regulated output voltage. A low equivalent series resistance (ESR) capacitor, typically 1 μ F, is required from OUT to ground for stability. Place the output capacitor as close to the OUT and GND pins of the device as possible. An internal 150 Ω (typical) pull-down resistor prevents a charge from remaining on V _{OUT} when the regulator shutdowns.

7. Absolute Maximum Ratings^[1]

PARAMETER		RATING	UNIT
Input Voltage Range		-0.3 to 6.0	V
EN Input Voltage Range		-0.3 to V_{IN}	
Output Voltage Range		-0.3 to V_{IN}	
Maximum Output Current		500 ^[2]	mA
Power Dissipation, $P_{D(MAX)}$ @ $T_A = 25^\circ\text{C}$		1046	mW
Thermal Resistance ^{[2] [4]} $R_{\theta JA}$		119.4	$^\circ\text{C/W}$
Thermal Resistance ^{[2] [3]} $R_{\theta JB}$		89.09	
Top Thermal Resistance ^{[2] [3]} $R_{\theta JC}$		48.9	
Bottom Thermal Resistance ^{[2] [3]} $R_{\theta JC}$		26.36	
Junction Temperature		150	$^\circ\text{C}$
Lead Temperature Range		260	
Storage Temperature Range		-55 to 150	
ESD Susceptibility	HBM	± 8000	V

NOTE1: Stresses beyond those listed under Absolute Maximum Ratings may cause permanent damage to the device. These are stress ratings only, which do not imply functional operation of the device at these or any other conditions beyond those indicated under Recommended Operating Conditions. Exposure to absolute-maximum-rated conditions for extended periods may affect device reliability.

NOTE2: Measured on 2cm x 2cm 2-layer FR4 PCB board, 1 oz copper, no via holes on GND copper.

NOTE3: Measured according to JEDEC board specification. Detailed description of the board can be found in JESD51-7.

NOTE4: Power dissipation is calculate by $P_{D(MAX)} = (T_J - T_A) / R_{\theta JA}$.

8. Recommended Operating Conditions

PARAMETER	MIN	MAX	UNIT
Input voltage range	2.2	5.5	V
EN Input voltage range	0	5.5	
Nominal output voltage range	1.0	3.3	
Output current	0	300	mA
Input capacitor	1		μF
Output capacitor	1		
Operating temperature range	-40	125	°C

9. Electrical Characteristics

($V_{IN}=V_{OUT(NOMINAL)}+1V$, $C_{IN}=C_{OUT}=1\mu F$, $T_A=25^\circ C$, unless otherwise noted)

SYMBOL	PARAMETER	TEST CONDITIONS	MIN	TYP.	MAX	UNIT
V_{OUT}	Output Voltage Range	$V_{OUT} \leq 1.5V$, $V_{IN}=2.7V$, $I_{OUT}=1mA$	0.97 V_{OUT}	V_{OUT}	1.03 V_{OUT}	V
		$V_{OUT} > 1.5V$, $I_{OUT}=1mA$	0.98 V_{OUT}	V_{OUT}	1.02 V_{OUT}	
V_{DO}	Dropout Voltage ^[1]	$V_{OUT}=3.3V$, $I_{OUT}=300mA$		220	330	mV
		$V_{OUT}=3.0V$, $I_{OUT}=300mA$		240	360	
		$V_{OUT}=2.8V$, $I_{OUT}=300mA$		250	375	
		$V_{OUT}=2.5V$, $I_{OUT}=300mA$		280	420	
		$V_{OUT}=2.2V$, $I_{OUT}=300mA$		310	465	
		$V_{OUT}=1.8V$, $I_{OUT}=300mA$		400	600	
		$V_{OUT} \leq 1.5V$, $I_{OUT}=300mA$	$V_{IN} \geq 2.2V$			
I_{LIM}	Output Current Limit	$V_{EN}=V_{IN}$		500		mA
I_{OUT}	Maximum Output Current in the Accuracy Range	$V_{EN}=V_{IN}$	300			mA
I_{SHORT}	Short Current	$V_{EN}=V_{IN}$, V_{OUT} Short to GND		150		mA
LNR	Line Regulation	$V_{OUT}=3.3V$, $V_{IN}=4.3\sim 5.5V$, $I_{OUT}=1mA$		0.05	0.1	%/V
LDR	Load Regulation	$V_{OUT}=3.3V$, $I_{OUT}=1\sim 300mA$		15		mV
I_Q	Quiescent Current	$V_{OUT}=3.3V$, $I_{OUT}=0mA$		60	80	μA
I_{SHDN}	Shut-down Current	$V_{EN} = 0V$		0.1	1.0	μA
PSRR	Power Supply Ripple Rejection	$V_{IN}=(V_{OUT}+1V)_{DC}+0.5V_{P-P}$ $f=1kHz$, $I_{OUT}=10mA$, @ $V_{OUT}=3.3V$		70		dB
		$V_{IN}=(V_{OUT}+1V)_{DC}+0.5V_{P-P}$ $f=10kHz$, $I_{OUT}=10mA$, @ $V_{OUT}=3.3V$		55		

SYMBOL	PARAMETER	TEST CONDITIONS	MIN	TYP.	MAX	UNIT
V_{NO}	Output Noise Voltage	BW = 10Hz to 100kHz, $V_{OUT} = 3.3\text{ V}$, $I_{OUT} = 10\text{ mA}$, $C_{OUT} = 1\mu\text{F}$		140		μV_{RMS}
V_{ENH}	EN High Voltage (enabled)	$V_{IN} = 5.5\text{V}$, $I_{OUT} = 1\text{mA}$	1.2			V
V_{ENL}	EN Low Voltage (disabled)	$V_{IN} = 5.5\text{V}$, $I_{OUT} = 1\text{mA}$			0.4	V
T_{SD}	Thermal Shutdown Threshold			165		$^{\circ}\text{C}$
ΔT_{SD}	Thermal Shutdown Hysteresis			30		$^{\circ}\text{C}$
R_{DIS}	Output Discharge Resistance	$V_{IN} = 4.0\text{V}$, $V_{EN} = 0\text{V}$		150		Ω

Note1: The dropout voltage is defined as $(V_{IN} - V_{OUT})$ when V_{OUT} is $V_{OUT(NOM)} * 98\%$. V_{DO} is measured for devices with $V_{OUT(NOM)} \geq 1.8\text{V}$.

Note2: Maximum output current is affected by the PCB layout, size of metal trace, the thermal conduction path between metal layers, ambient temperature and the other environment factors of system. Attention should be paid to the dropout voltage when $V_{IN} < V_{OUT} + V_{DROP}$.

Note3: The load regulation is measured by pulse test.

10. Typical Performance Characteristics

($V_{IN}=V_{OUT(NOM)}+1V$, $C_{IN}=C_{OUT}=1\mu F$, unless otherwise noted)

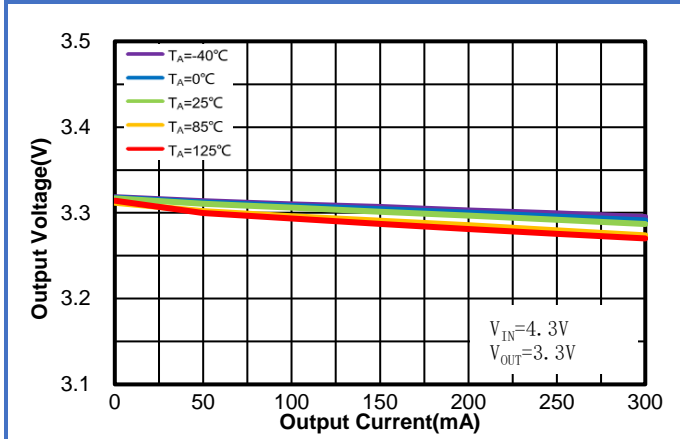

Figure 1. WR0332-33A50R-AT
Load Regulation vs. I_{OUT} & Ambient Temperature

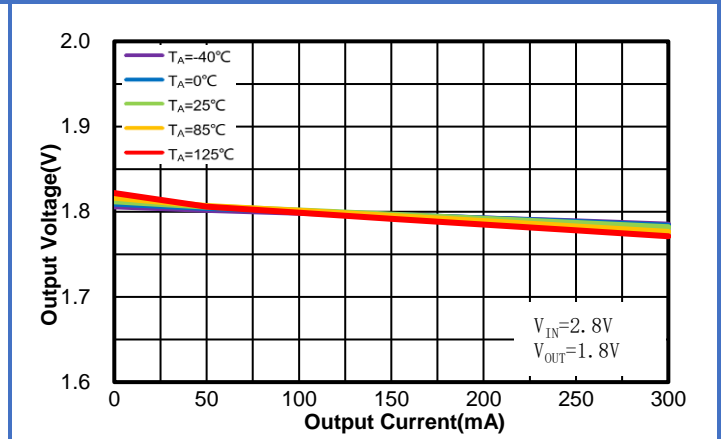

Figure 2. WR0332-18A50R-AT
Load Regulation vs. I_{OUT} & Ambient Temperature

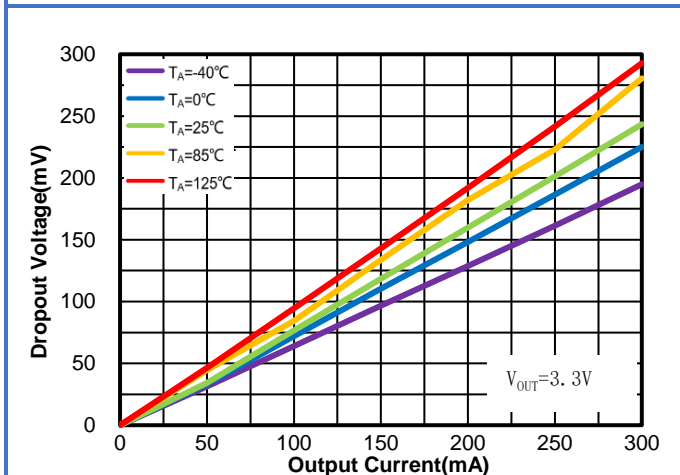

Figure 3. WR0332-33A50R-AT
Dropout Voltage vs. I_{OUT} & Ambient Temperature

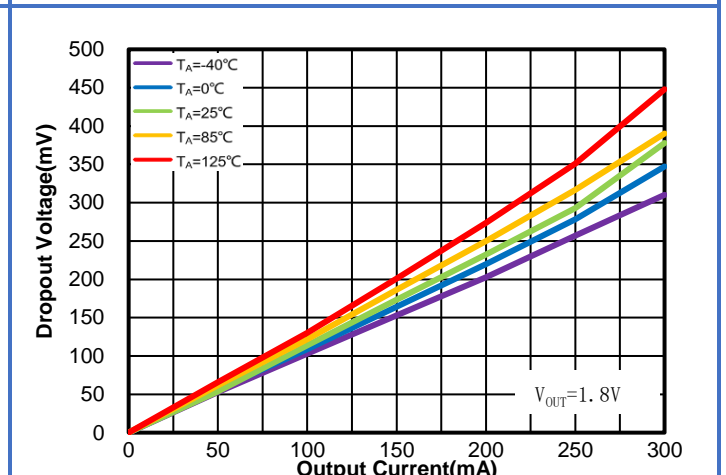

Figure 4. WR0332-18A50R-AT
Dropout Voltage vs. I_{OUT} & Ambient Temperature

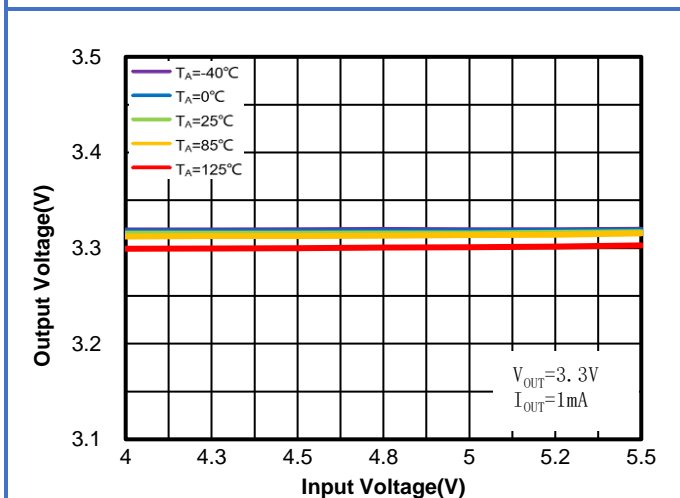

Figure 5. WR0332-33A50R-AT
Regulation vs. V_{IN} (Line Regulation) & Ambient Temperature

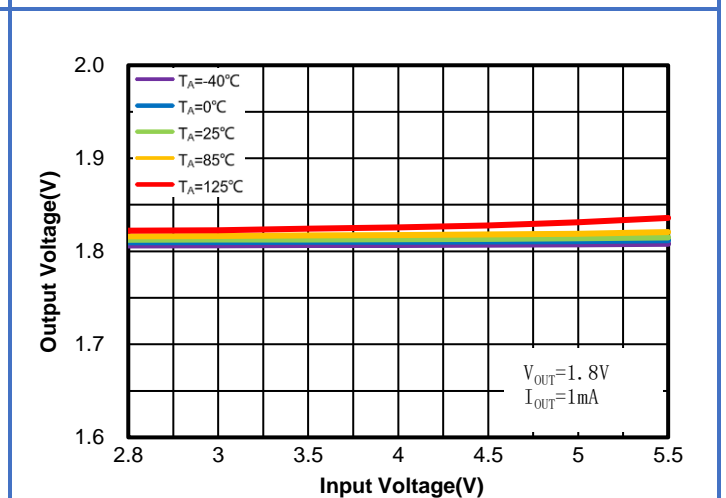

Figure 6. WR0332-18A50R-AT
Regulation vs. V_{IN} (Line Regulation) & Ambient Temperature

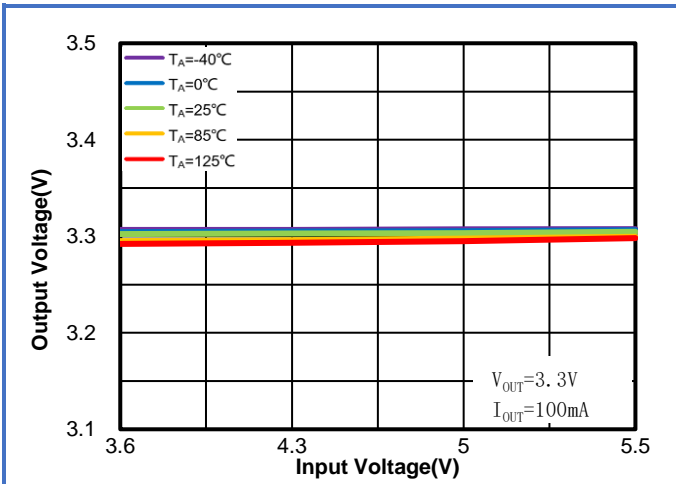

Figure 7. WR0332-33A50R-AT

Regulation vs. V_{IN} (Line Regulation) & Ambient Temperature

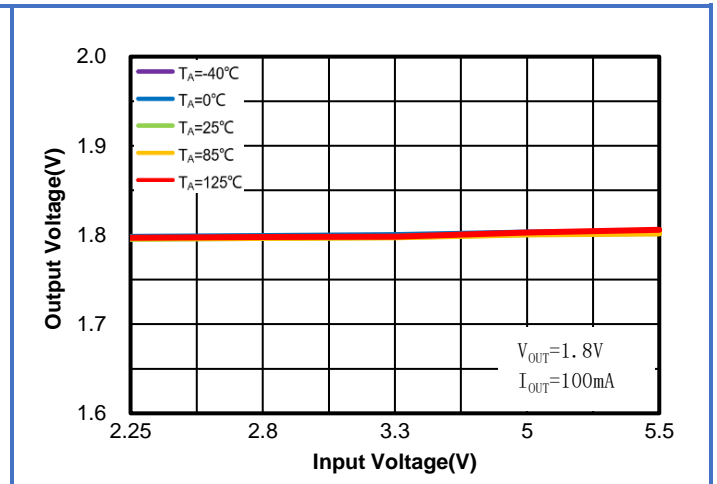

Figure 8. WR0332-18A50R-AT

Regulation vs. V_{IN} (Line Regulation) & Ambient Temperature

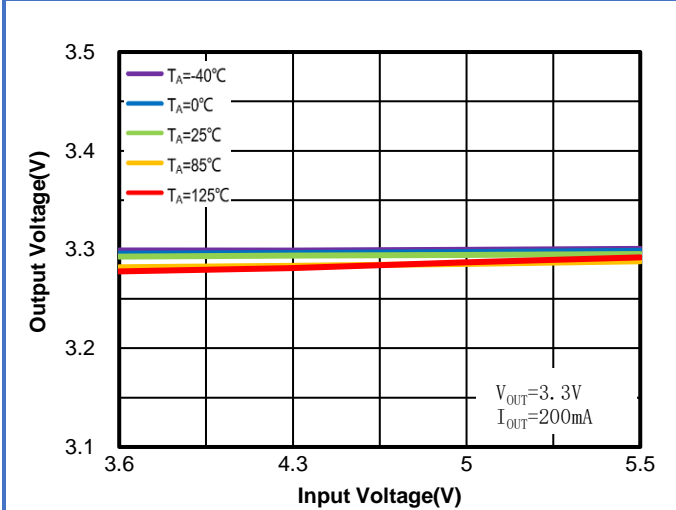

Figure 9. WR0332-33A50R-AT

Regulation vs. V_{IN} (Line Regulation) & Ambient Temperature

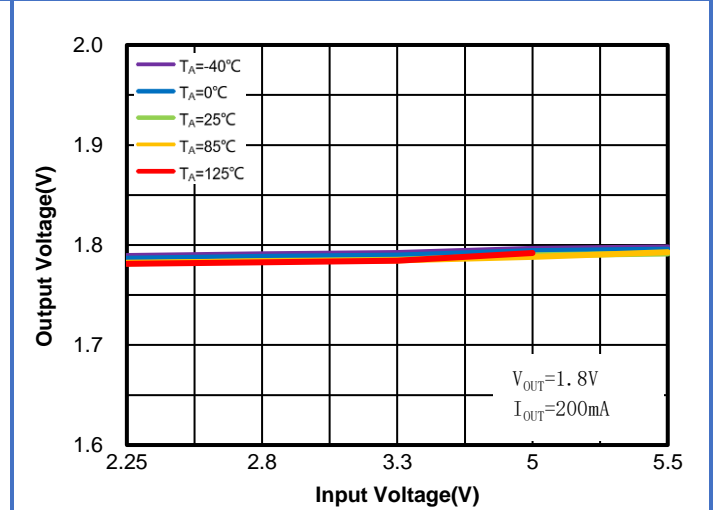

Figure 10. WR0332-18A50R-AT

Regulation vs. V_{IN} (Line Regulation) & Ambient Temperature

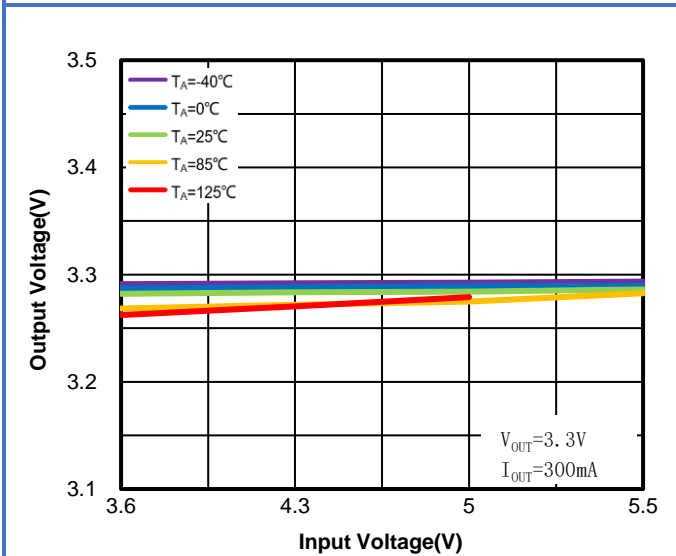

Figure 11. WR0332-33A50R-AT

Regulation vs. V_{IN} (Line Regulation) & Ambient Temperature

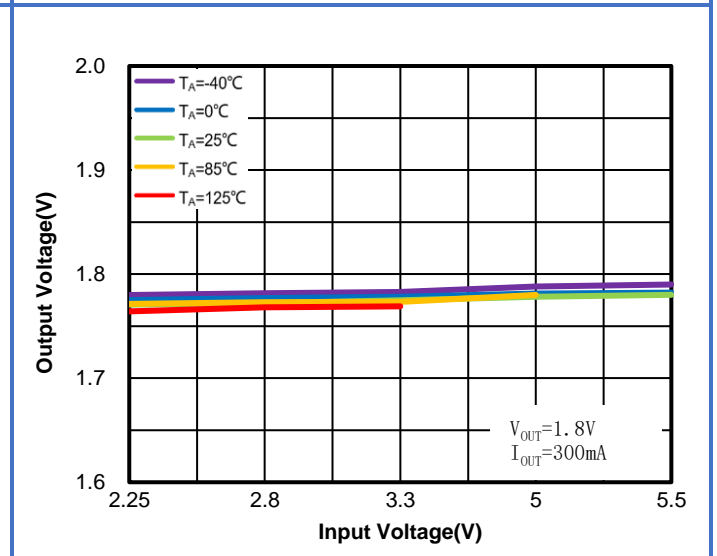

Figure 12. WR0332-18A50R-AT

Regulation vs. V_{IN} (Line Regulation) & Ambient Temperature

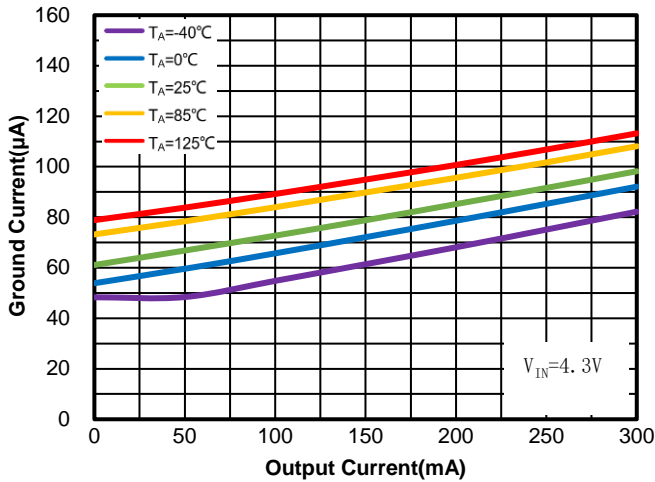

Figure 13. WR0332-33A50R-AT

Ground Pin Current vs. I_{OUT} & Ambient Temperature

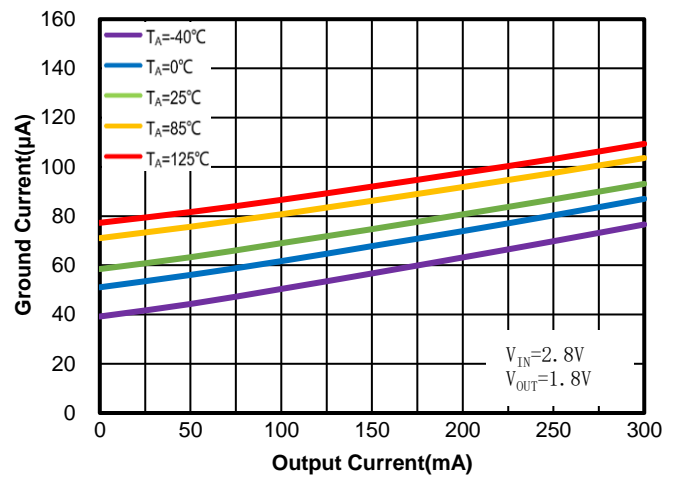

Figure 14. WR0332-18A50R-AT

Ground Pin Current vs. I_{OUT} & Ambient Temperature

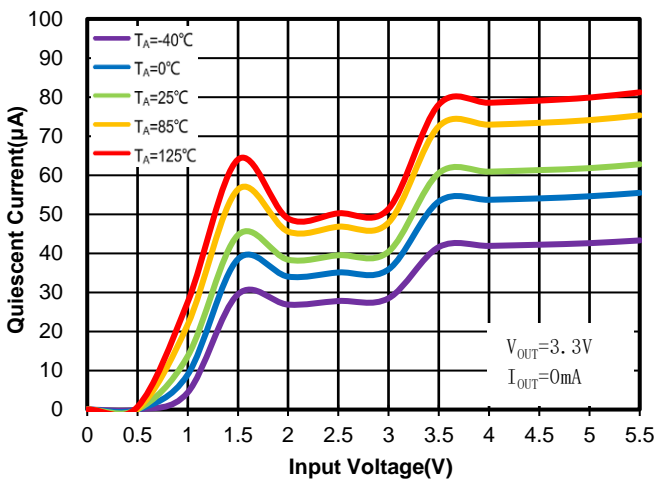

Figure 15. WR0332-33A50R-AT

Quiescent Current vs. V_{IN} & Ambient Temperature

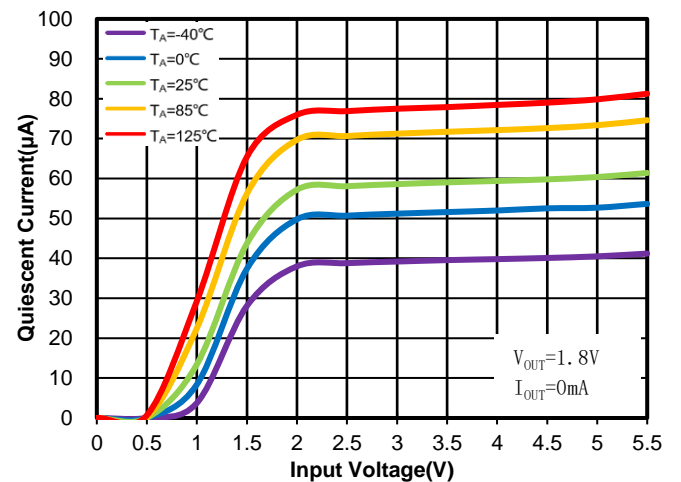

Figure 16. WR0332-18A50R-AT

Quiescent Current vs. V_{IN} & Ambient Temperature

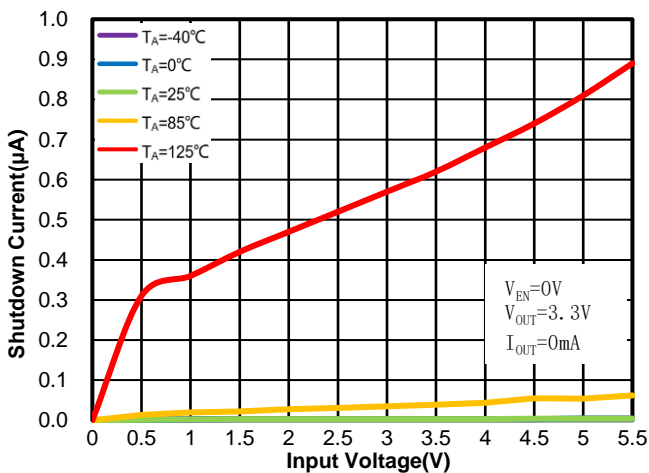

Figure 17. WR0332-33A50R-AT

Shutdown Current vs. V_{IN} & Ambient Temperature

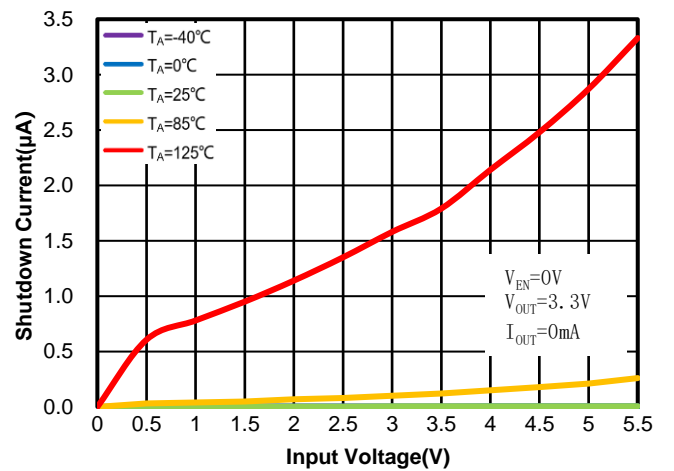
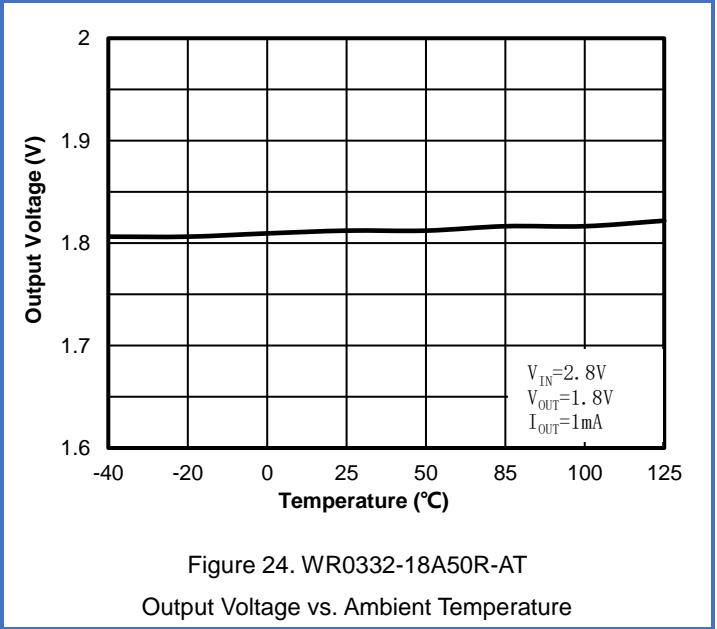
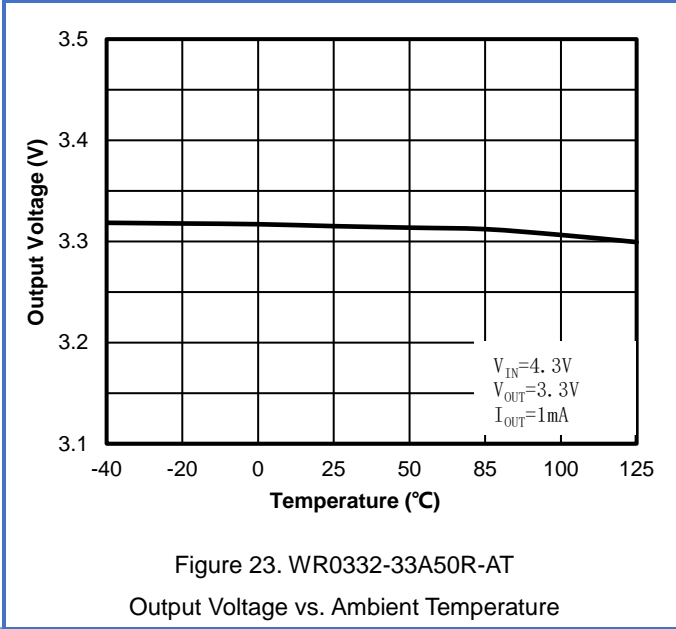
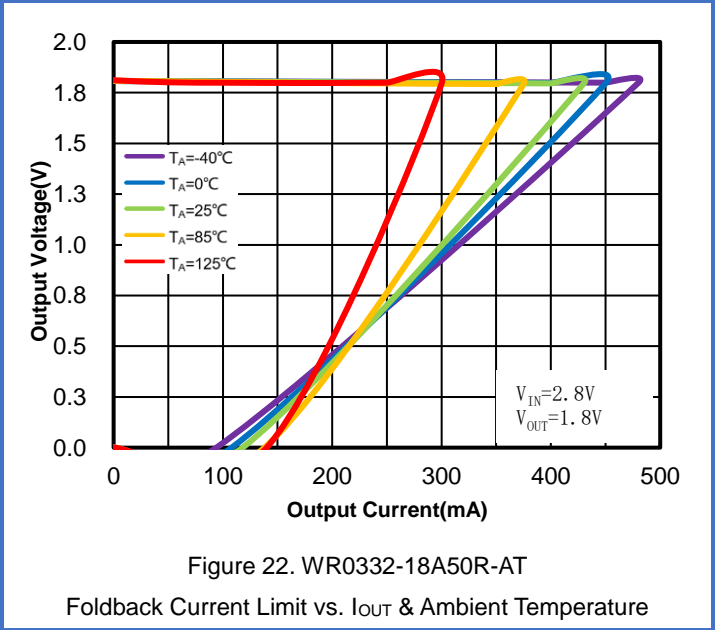
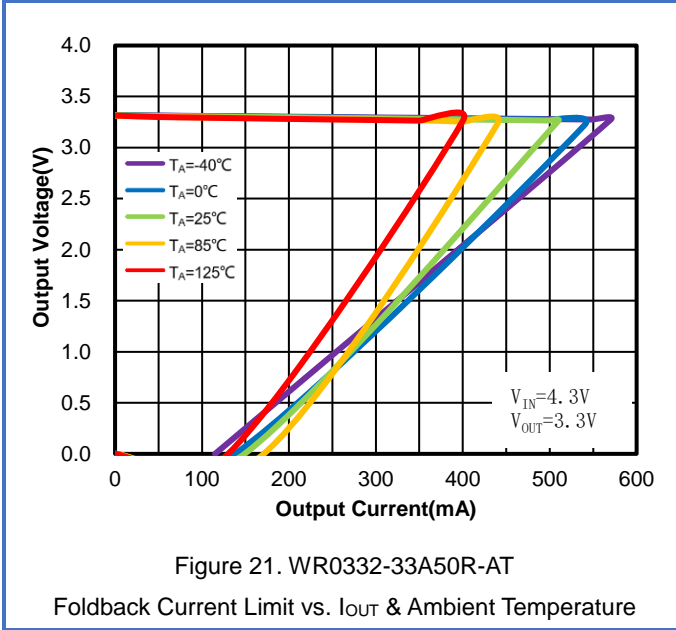
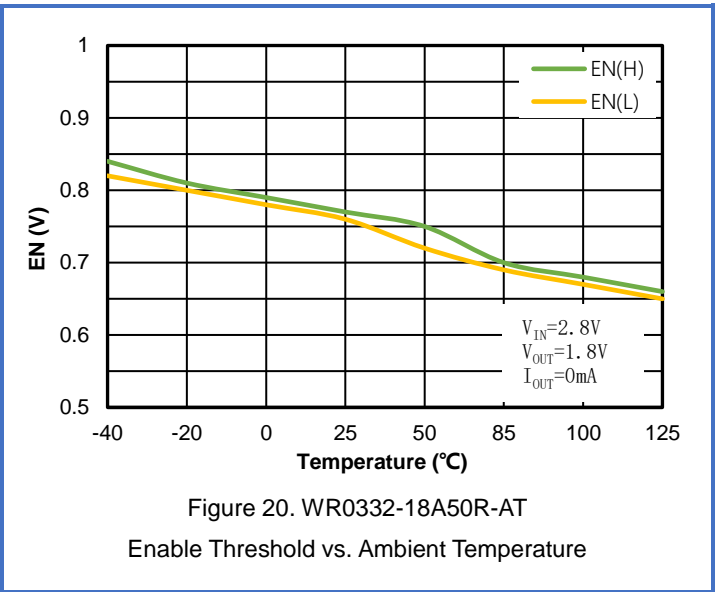
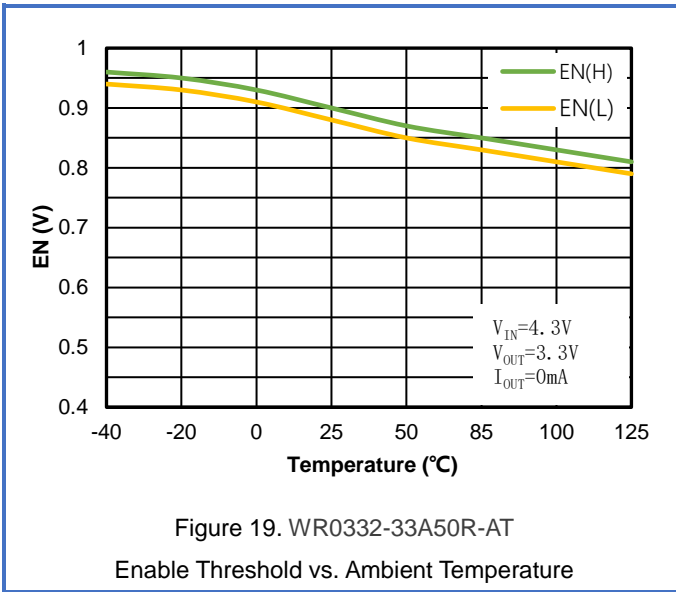

Figure 18. WR0332-18A50R-AT

Shutdown Current vs. V_{IN} & Ambient Temperature



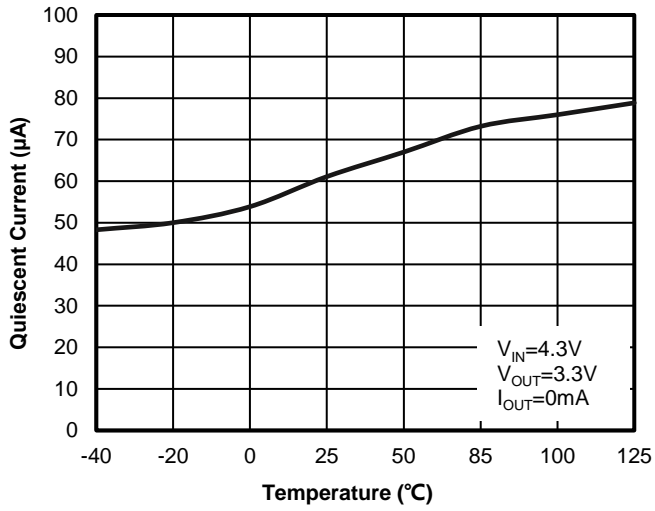

Figure 25. WR0332-33A50R-AT
Quiescent Current vs. Ambient Temperature

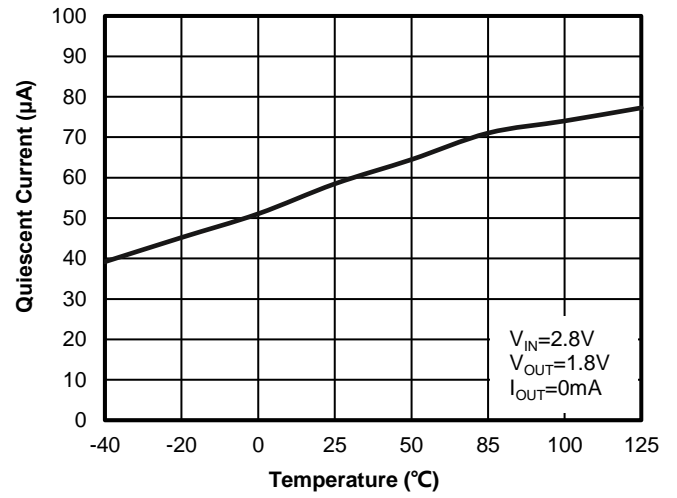

Figure 26. WR0332-18A50R-AT
Quiescent Current vs. Ambient Temperature

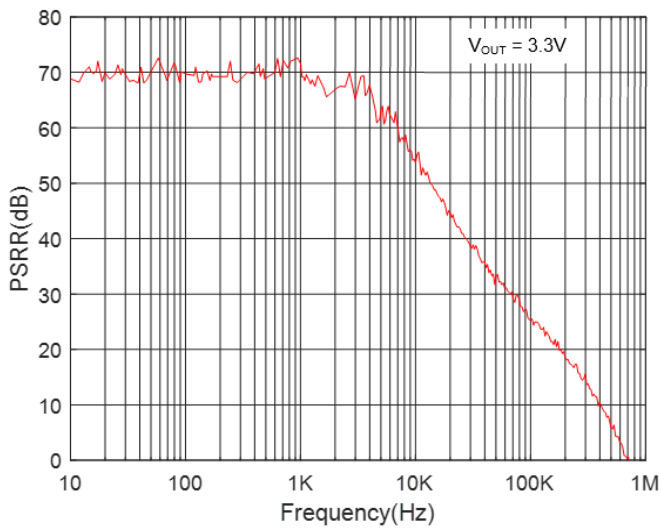

Figure 27. Power Supply Rejection Ratio vs. Frequency

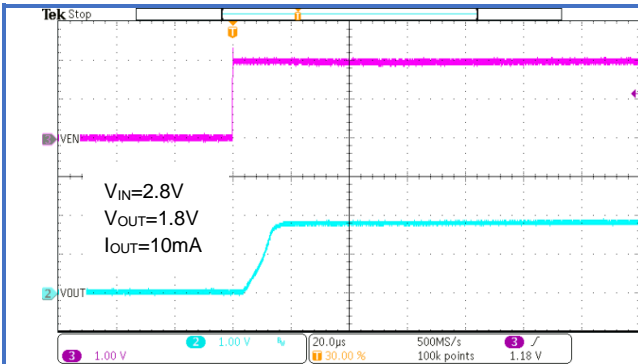

Figure 28. Soft Start from EN

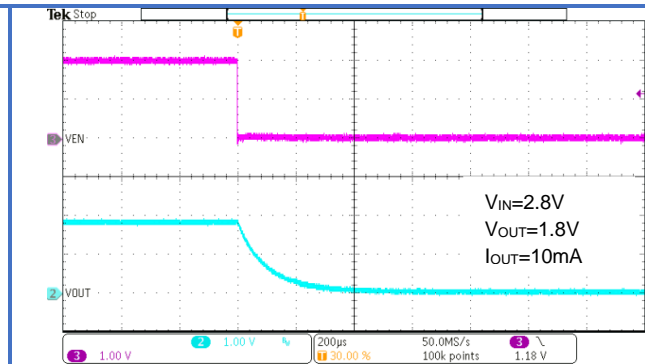

Figure 29. EN Shutdown

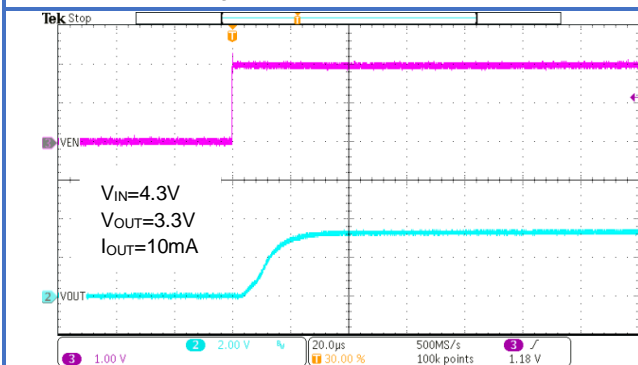

Figure 30. Soft Start from EN

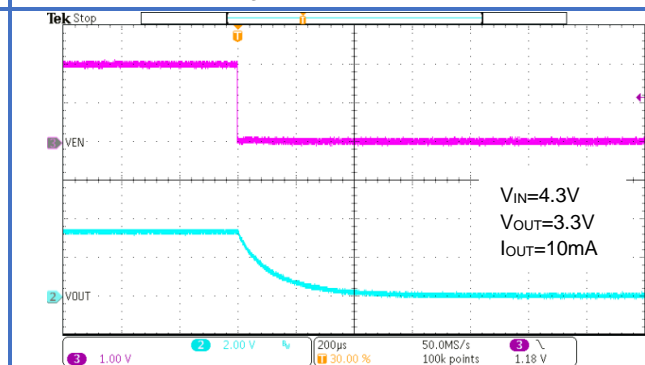

Figure 31. EN Shutdown

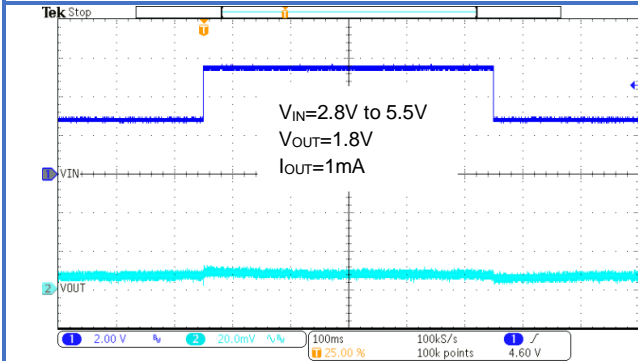

Figure 32. Line Transient

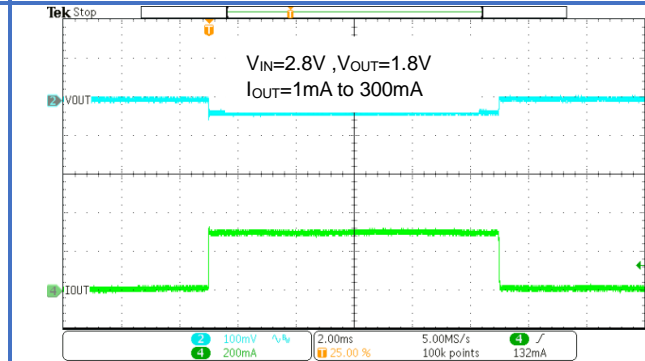

Figure 33. Load Transient

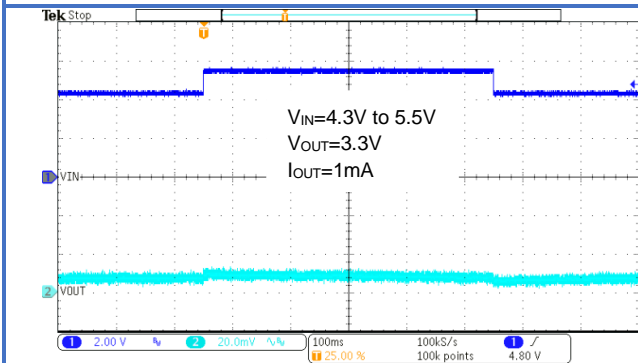

Figure 34. Line Transient

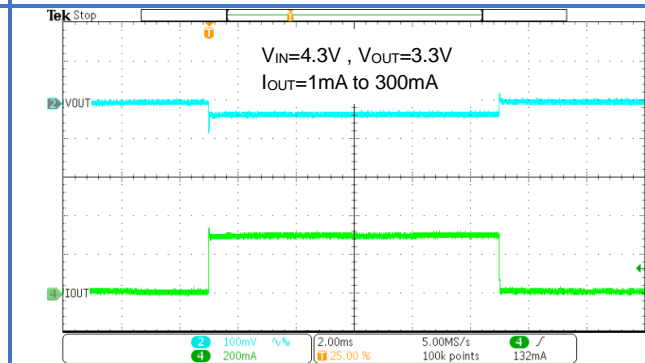

Figure 35. Load Transient

11. Function Description

11.1 Overview

The WR0332-AT is high performance high PSRR regulator capable of supplying 300mA and providing wide output voltage range. The device also offers low quiescent current, low-dropout voltage and very small packages suitable for space constrains application. The WR0332-AT is designed to be used in a variety of applications.

11.2 Block Diagram

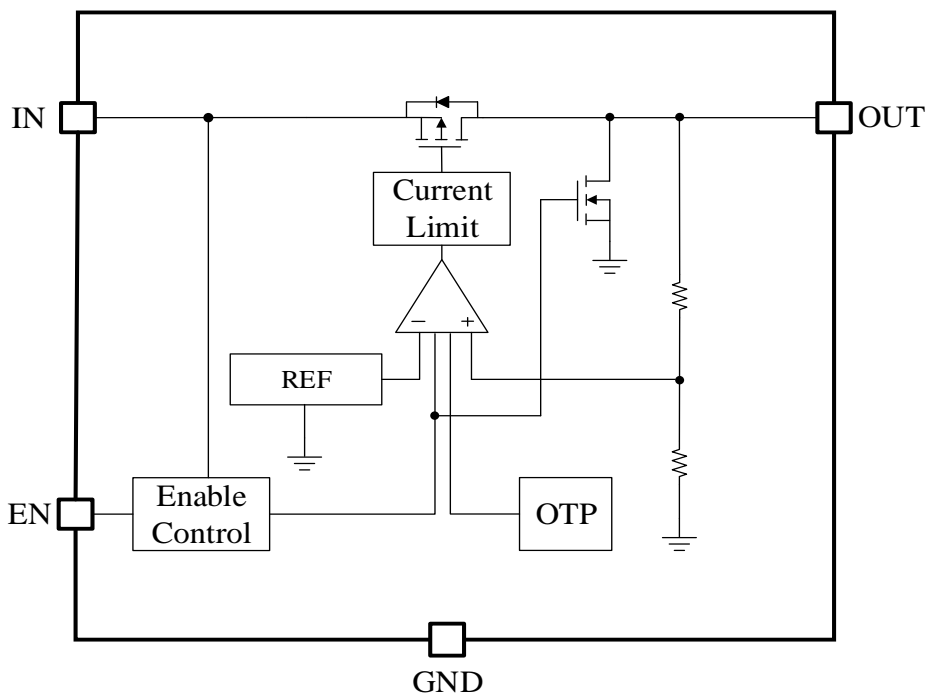

11.3 Feature Description

11.3.1 Output Voltage Accuracy

The WR0332-AT has an output voltage accuracy of 2% or 3%. Output voltage accuracy is defined as the maximum and minimum error in output voltage. This includes the errors introduced by internal reference, load regulation and line regulation differences over the full range of rated load and line operating conditions, taking into account differences between manufacturing lots.

11.3.2 Enable (EN)

The WR0332-AT EN pin has internal pull-up current source with value of 100nA typ. When the input voltage of the enable pin is higher than the high enable voltage threshold, the device outputs normally. When the input voltage of the enable pin is lower than the low input voltage threshold of the EN pin, the device outputs shutdown. If you do not need to control the output voltage independently, connect the enable pin to the input of the device.

11.3.3 Dropout Voltage (V_{DO})

WR0332-AT is a low dropout voltage LDO that can achieve nominal output voltage at lower input voltages. Dropout voltage is defined as the minimum of $(V_{IN}-V_{OUT})$ at the rated maximum output current where V_{OUT} is the minimum of $V_{OUT(NOM)}$. When the input voltage is below $V_{OUT(NOM)}$ plus V_{DO} , the output voltage varies with the input voltage.

For a CMOS regulator, the dropout voltage is determined by the drain-source on-state resistance ($R_{DS(ON)}$) of the pass transistor. Therefore, if the linear regulator operates at less than the rated current, the dropout voltage for that current scales accordingly. The $R_{DS(ON)}$ is calculated by following equation.

$$R_{DS(ON)}=V_{DO}/I_{OUT}$$

11.3.4 Power Supply Rejection Ratio (PSRR)

PSRR, which stands for Power Supply Rejection Ratio, represents the ratio of the two voltage gains obtained when the input and output power supplies are considered as two independent sources.

The basic calculation formula is

$$PSRR = 20\lg(\text{Ripple(in)} / \text{Ripple(out)})$$

The units are in decibels (dB) and the logarithmic ratio is used.

The above equation shows that the output signal is influenced by the power supply in general, in addition to the circuit itself. PSRR is a quantity used to describe how the output signal is affected by the power supply; the larger the PSRR, the less the output signal is affected by the power supply.

As the level of integration continues to increase, the magnitude of supply current required is also increasing. End users want to extend battery life, i.e. they need very efficient DC/DC conversion processes, using more efficient switching regulators. However, switching regulators generate more ripple in the power line than linear regulators.

The PSRR shows the ability of the LDO to suppress input voltage noise. For a clean, noise-free DC output voltage, use an LDO with a high PSRR.

Noise coupling from the input voltage to the internal reference voltage is the main cause of PSRR performance degradation. Using noise reduction capacitors at the input can effectively filter out noise and improve PSRR performance at low frequencies. The LDO can be used not only to regulate the voltage but also to provide an exceptionally clean DC supply for noise sensitive components.

The WR0332-AT is a high PSRR LDO that can be used not only for voltage regulation but also for noise cancellation in the power supply.

11.3.5 Noise

LDO noise can be divided into two main categories: internal noise and external noise. Internal noise is the noise generated inside the electronics; external noise is the noise transmitted from outside the circuit to the circuit. The error amplifier determines the PSRR of the LDO and therefore its ability to suppress external noise at the input; internal noise is always present at the output of the LDO.

In practice, minimizing noise from the power supply is critical to system performance. In test and measurement systems, small fluctuations in power supply noise can alter the instantaneous measurement accuracy.

The WR0332-AT has a low noise reference, high PSRR to ensure that output noise is reduced during normal operation.

11.3.6 Foldback Current Limit (I_{LIM})

In LDO circuits, if an output short circuit or excessive load current occurs, the device may be burned out. Especially in the case of a short circuit, not only is there too much current flowing through the regulator, but the voltage across the source drain of the regulator is also at its maximum, which is likely to burn out the regulator and make the device inoperable. The current limiting circuit used in LDO is a constant current limiting circuit, where the maximum load current that the LDO can supply is limited to a set constant I_{LIM} , and when an overload or short circuit occurs, the output current will be maintained at I_{LIM} , and the output voltage will be reduced to $I_{LIM}R_{LOAD}$.

However, if the external overload or short circuit condition lasts for a long time, the continuous high current will increase the device temperature and increase the power consumption of the whole system. To improve this situation, a foldback current limiting circuit can be used. In a foldback current limiting circuit, both the output current and the output voltage are gradually reduced when the output current reaches the set maximum current I_{LIM} . The output current is reduced to the set current threshold I_{SHORT} and the output voltage is reduced to $I_{SHORT}R_{LOAD}$. The output current is clamped to a smaller value in the event of an overload or short circuit and the system power consumption is reduced and the device temperature does not rise significantly.

The foldback current limiting circuit is essentially a constant current limiting circuit with an output voltage feedback loop, so that in the event of an overload or short circuit, the output current is gradually reduced due to the reduction in output voltage and eventually clamped at a smaller value.

The WR0332-AT uses a foldback current limiting mode where the final current is clamped to around 150mA, thus providing good protection to the device.

More information on current limiting can be found in Electrical Characteristics Figure 21 to Figure 22.

11.3.7 Thermal Protection

The WR0332-AT contains a thermal shutdown protection circuit that implements the required switching gate circuit function through a thermal switch integrated inside the chip. The output current is turned off when the heat in the LDO is too high. Thermal shutdown occurs when the thermal junction temperature (T_J) of the energized crystal exceeds 165°C (typical). The thermal shutdown hysteresis ensures that the LDO resets (turns on) again when the temperature drops to 135°C (typical). The thermal time constant of the semiconductor chip is quite short, so when thermal shutdown is reached, the output turns on and off at a higher rate until the power dissipation is reduced.

The WR0332-AT's internal protection circuitry is designed to prevent thermal overload conditions. This circuitry is not a substitute for a proper heat sink. Continuously putting the WR0332-AT into a thermal shutdown state will reduce the reliability of the device.

11.4 Functional Mode of the Device

The device has three modes: normal, dropout, and disabled modes of operation.

The operating conditions of each mode are listed in the table below.

Operating conditions of each mode

FUNCTIONAL MODE	CONDITIONS			
	V_{IN}	V_{EN}	I_{OUT}	T_J
Normal	$5.5V > V_{IN} > V_{OUT(NOM)} + V_{DO}$	$V_{EN} > V_{ENH}$	$I_{OUT} < I_{LIM}$	$T_J < T_{SD}$
Dropout	$V_{IN} < V_{OUT(NOM)} + V_{DO}$	$V_{EN} > V_{ENH}$	$I_{OUT} < I_{LIM}$	$T_J < T_{SD}$
Disabled	—	$V_{EN} < V_{ENL}$	—	$T_J > T_{SD}$

11.4.1 Normal Mode

Normal operating mode requires that both of the following conditions are met.

1. The input voltage is greater than the rated output voltage plus the differential voltage ($V_{OUT(NOM)} + V_{DO}$) and is less than 5.5V.
2. The enable voltage has previously exceeded the enable rise threshold voltage and has not fallen below the enable fall threshold.
3. The output current is less than the current limit ($I_{OUT} < I_{LIM}$).
4. The device junction temperature is less than the thermal shutdown temperature ($T_J < T_{SD}$).

11.4.2 Dropout Mode

If the input voltage is below the rated output voltage plus a specified dropout voltage, the device operates in the dropout state and the output voltage tracks the input voltage.

11.4.3 Disabled

The WR0332-AT can be turned off by forcing the enable pin low, typically with an enable voltage below 0.4V, at which point the pass device is turned off, internal circuits are shutdown, and the output voltage is actively discharged to ground through an internal resistor from output to ground.

12. Application and Implementation

Note: The information in the Applications section below is not part of WAY-ON's product specifications and WAY-ON does not guarantee its accuracy or completeness. The customer is responsible for determining the suitability of the component for its intended use and should verify and test its design implementation to confirm system functionality.

12.1 Application Information

The WR0332-AT is a linear voltage regulator with an input voltage of 2.2V to 5.5V and an output voltage of 1.0V to 3.3V. The accuracy is 3% for output voltages up to 1.5V and 2% for output voltages greater than 1.5V. The maximum output current is 300mA. The efficiency of a linear voltage regulator is determined by the ratio of the output voltage to the input voltage, so in order to achieve high efficiency, the differential voltage ($V_{IN} - V_{OUT}$) must be as small as possible. This section discusses how best to use this device in practical applications.

12.1.1 Capacitor Recommendation

The WR0332-AT uses ceramic capacitors with low equivalent series resistance (ESR) at the V_{IN} and V_{OUT} pins to increase its stability. Multilayer ceramic capacitors are recommended. These capacitors also have limitations, and ceramic capacitors with X7R-, X5R-, and COG-rated dielectric materials have relatively good capacitance stability at different temperatures. WR0332-AT is designed to use ceramic capacitors of 1 μ F or larger at the input and output. Place C_{IN} and C_{OUT} as close to the IN and OUT pins as possible to minimize trace inductance from the capacitor to the device.

12.1.2 Power Dissipation (P_D)

The reliability of the circuit requires reasonable consideration of the power dissipation of the device, the location of the circuit on the PCB, and the proper sizing of the thermal plane. The regulator should be surrounded by no other heat generating devices as much as possible. The power dissipation of the regulator depends on the input and output voltage difference and the load conditions.

P_D can be calculated using the following equation:

$$P_D = (V_{IN} - V_{OUT}) \times I_{OUT}$$

Using the proper input voltage minimizes the power dissipation, resulting in greater efficiency. To obtain the lowest power dissipation, use the minimum input voltage required for normal output voltage.

The maximum power dissipation determines the maximum allowable ambient temperature (T_A) of the device. Power dissipation and junction temperature are typically related to the junction-ambient thermal resistance (θ_{JA}) and ambient air temperature (T_A) of the PCB and package and are calculated as follows

$$T_J = T_A + (\theta_{JA} \times P_D)$$

The thermal resistance (θ_{JA}) depends primarily on the thermal dispersion capability of the PCB design. The total copper area, copper weight, and the location of the plane all affect the thermal dispersion capability, and the PCB and copper laydown area can only be used as a relative measure of the package's thermal performance.

12.2 Typical Application

This section discusses the application of the WR0332-AT in the circuit. The following figure shows the schematic of the application circuit.

Circuit schematic 1: EN is connected to IN.

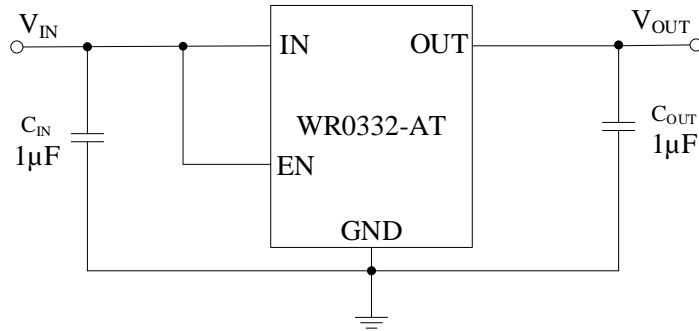

Circuit schematic 2: EN is controlled by external voltage.

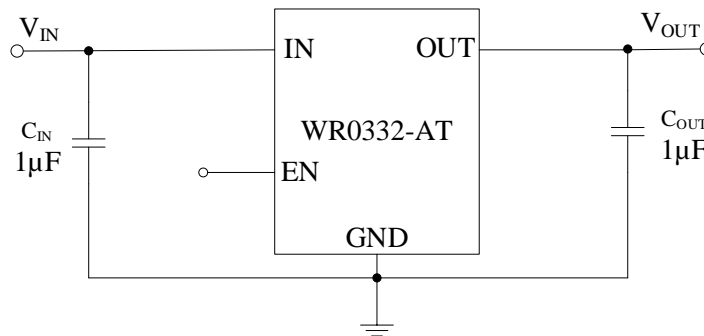

A minimum 1.0µF input capacitor(C_{IN}) is recommended to minimize the effect of resistance and inductance between the source and the LDO input. A minimum 1.0µF output capacitor(C_{OUT}) is also recommended for stability and good load transient response.

13. Power Supply Recommendations

The WR0332-AT has a V_{IN} range of between 2.2V and 5.5V and an input capacitance of 1µF. The input voltage should have some redundancy to ensure a stable output voltage when the load fluctuates. If the input supply is noisy, additional input capacitors can be used to improve the noise performance of the output.

14. Layout

The principle of LDO design is to place all components on the same side of the board and connect them as close as possible to their respective LDO pins. Connect the C_{IN} and C_{OUT} grounds, with all LDO ground pins as close together as possible, through a wide copper surface. Using through-holes and long wires for connections is strongly discouraged and can seriously affect system performance.

To improve thermal performance, an array of thermal vias is used to connect the thermal pad to the ground plane. A larger ground plane improves the thermal performance of the device and reduces the operating temperature of the device.

Layout Example

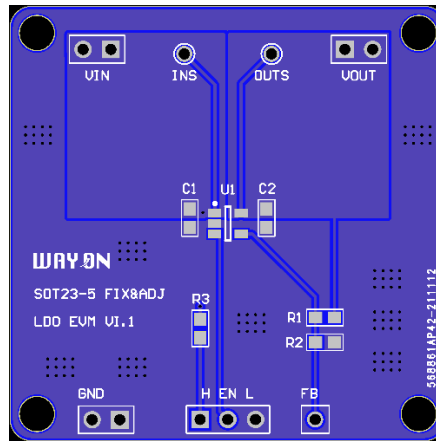

15. Evaluation Modules

Evaluation Modules (EVMs) are available to help evaluate initial circuit performance. We have evaluation modules for different packages, you can contact us by phone or address at the end to get the evaluation module or schematic.

The module names are listed in the table below.

NAME	PACKAGE	EVALUATION MODULE
WR0332-AT	SOT23-5	WAYON LDO EVM V1.1 -SOT23-5

16. Naming Conventions

WR AA BB-CC DDD E-AT

WR: WAYON Regulator

AA: 03 - Output Current, 300mA

BB: Serial Number

CC: Output Voltage

DDD: A50-Package, SOT23-5

E: R-Reel & T-tube

AT: Automotive

17. Electrostatic Discharge Warning

ESD can cause irreversible damage to integrated circuits, ranging from minor performance degradation to device failure. Precision ICs are more susceptible to damage because very minor parameter changes can cause the device to be out of compliance with its published specifications. WAY-ON recommends that all ICs be handled with proper precautions. Failure to follow proper handling practices and installation procedures may damage the IC.

18. Package Information

SOT 23-5

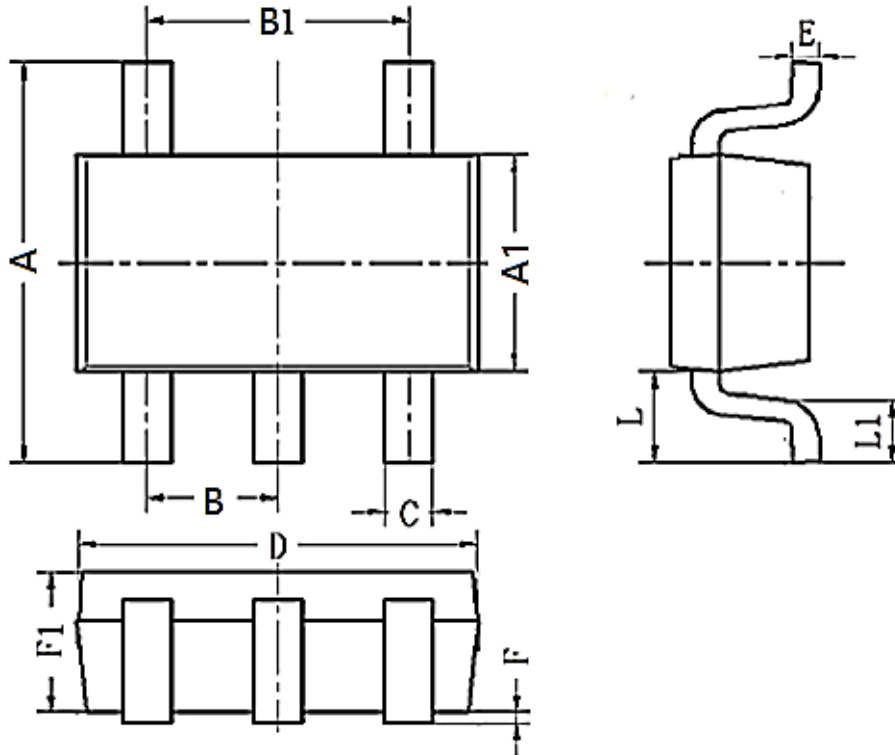

SYMBOL	DIMENSIONS IN MILLIMETERS		
	MIN	NOM	MAX
A	2.60	2.80	3.00
A1	1.50	1.60	1.70
B	0.85	0.95	1.05
B1	1.80	1.90	2.00
C	0.25	0.37	0.50
D	2.79	2.90	3.02
E	0.10	0.15	0.20
F	0.00	0.10	0.20
L	0.60REF		
L1	0.30	0.45	0.60
F1	0.85	1.10	1.30

19. Ordering Information

PART NUMBER	Output Voltage	PACKAGE	PACKING QUANTITY	MARKING*
WR0332-10A50R-AT	1.0V	SOT23-5	3k/Reel	0332Q 10 XXXX
WR0332-105A50R-AT	1.05V	SOT23-5	3k/Reel	0332Q 105 XXXX
WR0332-11A50R-AT	1.1V	SOT23-5	3k/Reel	0332Q 11 XXXX
WR0332-12A50R-AT	1.2V	SOT23-5	3k/Reel	0332Q 12 XXXX
WR0332-15A50R-AT	1.5V	SOT23-5	3k/Reel	0332Q 15 XXXX
WR0332-18A50R-AT	1.8V	SOT23-5	3k/Reel	0332Q 18 XXXX
WR0332-20A50R-AT	2.0V	SOT23-5	3k/Reel	0332Q 20 XXXX
WR0332-22A50R-AT	2.2V	SOT23-5	3k/Reel	0332Q 22 XXXX
WR0332-25A50R-AT	2.5V	SOT23-5	3k/Reel	0332Q 25 XXXX
WR0332-27A50R-AT	2.7V	SOT23-5	3k/Reel	0332Q 27 XXXX
WR0332-28A50R-AT	2.8V	SOT23-5	3k/Reel	0332Q 28 XXXX
WR0332-29A50R-AT	2.9V	SOT23-5	3k/Reel	0332Q 29 XXXX
WR0332-30A50R-AT	3.0V	SOT23-5	3k/Reel	0332Q 30 XXXX
WR0332-33A50R-AT	3.3V	SOT23-5	3k/Reel	0332Q 33 XXXX

* XXXX is variable.

Contact Information

No.1001, Shiwan(7) Road, Pudong District, Shanghai, P.R.China.201207

Tel: 86-21-50310888 Fax: 86-21-50757680 Email: market@way-on.com

WAYON website: <http://www.way-on.com>

For additional information, please contact your local Sales Representative.

WAYON® is registered trademark of Wayon Corporation.

Specifications are subject to change without notice.

The device characteristics and parameters in this data sheet can and do vary in different applications and actual device performance may vary over time.

Users should verify actual device performance in their specific applications.

Product Specification Statement

- The product specification aims to provide users with a reference regarding various product parameters, performance, and usage. It presents certain aspects of the product's performance in graphical form and is intended solely for users to select product and make product comparisons, enabling users to better understand and evaluate the characteristics and advantages of the product. It does not constitute any commitment, warranty, or guarantee.
- The product parameters described in the product specification are numerical values, characteristics, and functions obtained through actual testing or theoretical calculations of the product in an independent or ideal state. Due to the complexity of product applications and variations in test conditions and equipment, there may be slight fluctuations in parameter test values. WAYON shall not guarantee that the actual performance of the product when installed in the customer's system or equipment will be entirely consistent with the product specification, especially concerning dynamic parameters. It is recommended that users consult with professionals for product selection and system design. Users should also thoroughly validate and assess whether the actual parameters and performance when installed in their respective systems or equipment meet their requirements or expectations. Additionally, users should exercise caution in verifying product compatibility issues, and WAYON assumes no responsibility for the application of the product.
- WAYON strives to provide accurate and up-to-date information to the best of our ability. However, due to technical, human, or other reasons, WAYON cannot guarantee that the information provided in the product specification is entirely accurate and error-free. WAYON shall not be held responsible for any losses or damages resulting from the use or reliance on any information in these product specifications. WAYON reserves the right to revise or update the product specification and the products at any time without prior notice, and the user's continued use of the product specification is considered an acceptance of these revisions and updates. Prior to purchasing and using the product, users should verify the above information with WAYON to ensure that the product specification is the most current, effective, and complete. If users are particularly concerned about product parameters, please consult WAYON in detail or request relevant product test reports. Any data not explicitly mentioned in the product specification shall be subject to separate agreement.
- Users are advised to pay attention to the parameter limit values specified in the product specification and maintain a certain margin in design or application to ensure that the product does not exceed the parameter limit values defined in the product specification. This precaution should be taken to avoid exceeding one or more of the limit values, which may result in permanent irreversible damage to the product, ultimately affecting the quality and reliability of the system or equipment.
- The design of the product is intended to meet civilian needs and is not guaranteed for use in harsh environments or precision equipment. It is not recommended for use in systems or equipment such as medical devices, aircraft, nuclear power, and similar systems, where failures in these systems or equipment could reasonably be expected to result in personal injury. WAYON shall assume no responsibility for any consequences resulting from such usage.
- Users should also comply with relevant laws, regulations, policies, and standards when using the product specification. Users are responsible for the risks and liabilities arising from the use of the product specification and must ensure that it is not used for illegal purposes. Additionally, users should respect the intellectual property rights related to the product specification and refrain from infringing upon any third-party legal rights. WAYON shall assume no responsibility for any disputes or controversies arising from the above-mentioned issues in any form.