



# WS6413KC

## Transient Voltage Suppressor

### Features

- Solid-state silicon-avalanche technology
- Low operating and clamping voltage
- Up to four I/O lines of protection
- Low leakage
- Low operating voltage:5V

### IEC COMPATIBILITY (EN61000-4)

- IEC 61000-4-2 (ESD)  $\pm 15\text{kV}$  (air),  $\pm 12\text{kV}$  (contact)
- IEC 61000-4-4 (EFT) 40A (5/50ns)
- IEC 61000-4-5 (Lightning) 5A (8/20 $\mu\text{s}$ )

### Mechanical Characteristics

- DFN2510-10L package
- Marking: Marking Code
- Packaging: Tape and Reel
- RoHS Compliant & HF
- Device meets MSL1 requirement

### Circuit Diagram

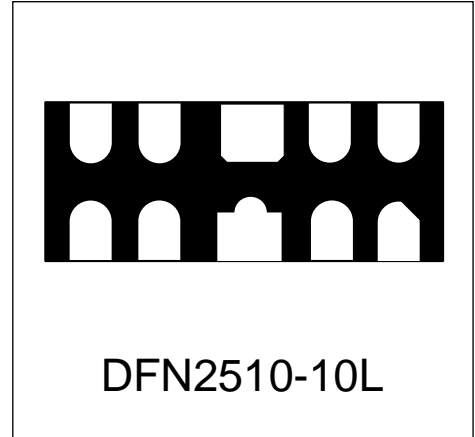
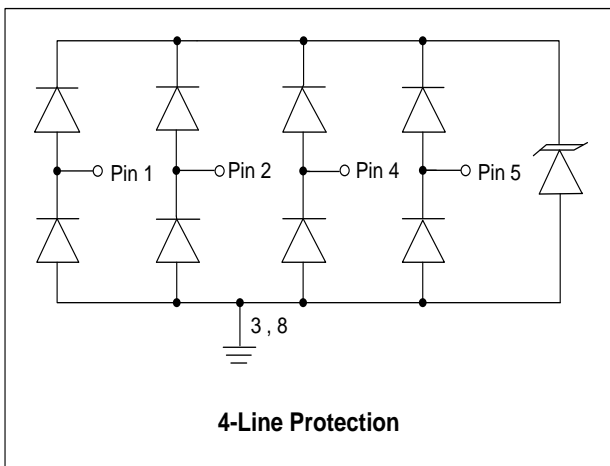

### Applications

- USB2.0 and USB 3.0
- HDMI 1.3, HDMI 1.4
- SATA and eSATA
- DVI
- IEEE 1394
- PCI Express
- Portable Electronics and Notebooks

### Schematic & PIN Configuration

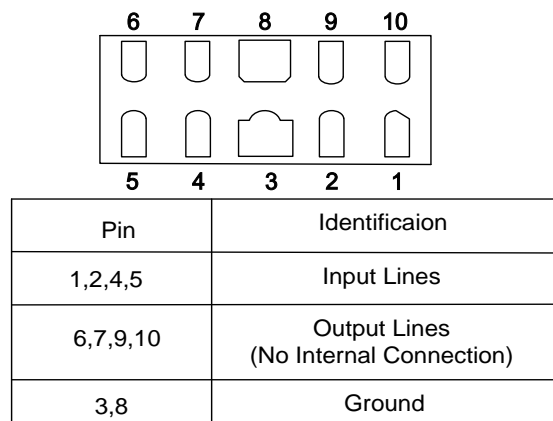

### Absolute Maximum Rating

Rating	Symbol	Value	Units
Peak Pulse Power ( $t_p = 8/20\mu s$ )	$P_{PP}$	25	W
Peak Pulse Current ( $t_p = 8/20\mu s$ )	$I_{pp}$	5	A
Operating Temperature	$T_J$	-55 to + 125	°C
Storage Temperature	$T_{STG}$	-55 to +150	°C

### Electrical Parameters

Symbol	Parameter
$I_{PP}$	Reverse Peak Pulse Current
$V_C$	Clamping Voltage
$V_{RWM}$	Reverse Stand-Off Voltage
$I_{BR}$	Reverse Breakdown Current
$I_R$	Reverse Leakage Current
$V_{BR}$	Reverse Breakdown Voltage
$V_T$	Reverse Trigger Voltage
$I_T$	Reverse Trigger Current
$V_H$	Reverse Holding Voltage
$I_H$	Reverse Holding current
$V_F$	Forward Voltage
$I_F$	Forward Current

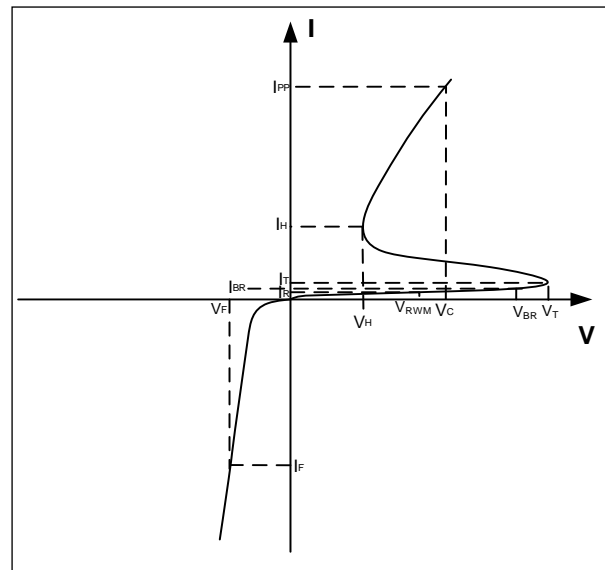

### Electrical Characteristics(T=25°C unless otherwise noted)

WS6413KC						
Parameter	Symbol	Conditions	Minimum	Typical	Maximum	Units
Reverse Stand-Off Voltage	$V_{RWM}$	Any I/O pin to ground			5	V
Reverse Breakdown Voltage	$V_{BR}$	$I_t = 1mA$ Any I/O pin to ground	5.6			V
Reverse Leakage Current	$I_R$	$V_{RWM} = 5V$ Any I/O pin to ground			500	nA
Holding current	$I_H$	$T = 25^\circ C$		9		mA
Clamping Voltage	$V_C$	$I_{pp} = 5A, t_p = 8/20\mu s$ Any I/O pin to ground		3	5	V
ESD Clamping Voltage <sup>1</sup>	$V_C$	$I_{pp} = 4A,$ $t_p = 0.2/100ns$ (TLP)		2.7		V
ESD Clamping Voltage <sup>1</sup>	$V_C$	$I_{pp} = 16A,$ $t_p = 0.2/100ns$ (TLP)		5.4		V
Dynamic Resistance <sup>1,2</sup>	$R_{DYN}$	TLP=0.2/100ns		0.23		$\Omega$
Junction Capacitance	$C_j$	$V_R = 2.5V, f = 1MHz$ I/O pin to GND		0.35	0.5	pF
		$V_R = 2.5V, f = 1MHz$ Between I/O pins,		0.18	0.25	pF

Notes : 1、 TLP Setting :  $t_p = 100ns, t_r = 0.2ns, I_{TLP}$  and  $V_{TLP}$  sample window:  $t_1 = 70ns$  to  $t_2 = 90ns$ .

2、 Dynamic resistance calculated from  $I_{PP} = 4A$  to  $I_{PP} = 16A$  using "Best Fit".

Typical Characteristics

Figure 1: Peak Pulse Power vs. Pulse Time

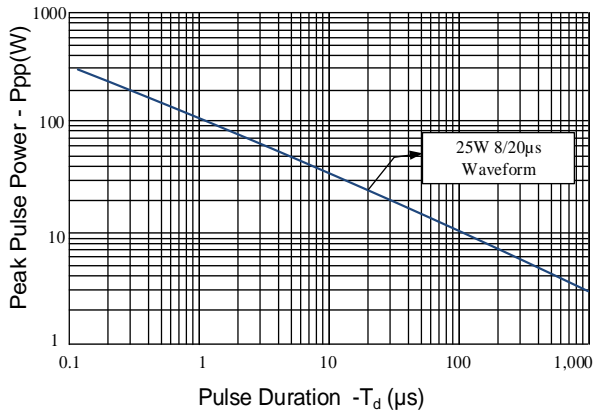

Figure 2: Power Derating Curve

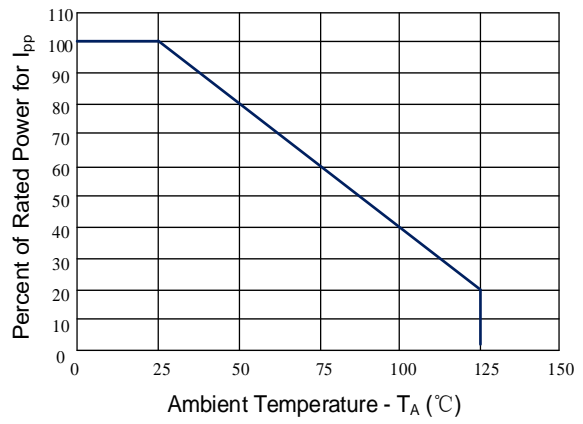

Figure 3: Clamping Voltage vs. Peak Pulse Current

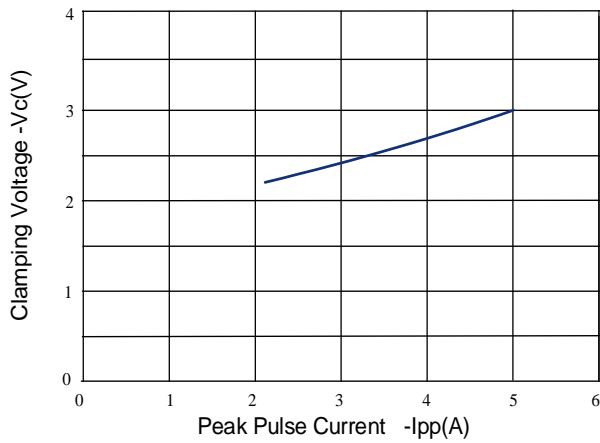

Figure 4: Normalized Junction Capacitance vs. Reverse Voltage

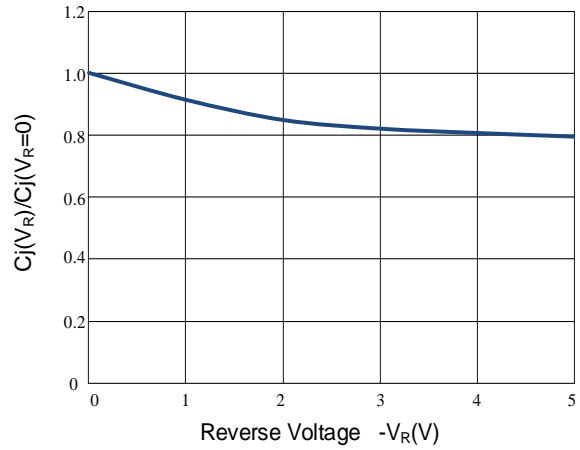

Figure 5: 8/20μs Pulse Waveform

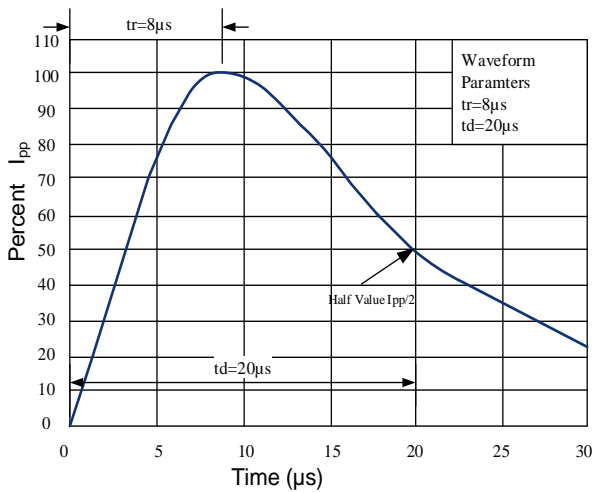
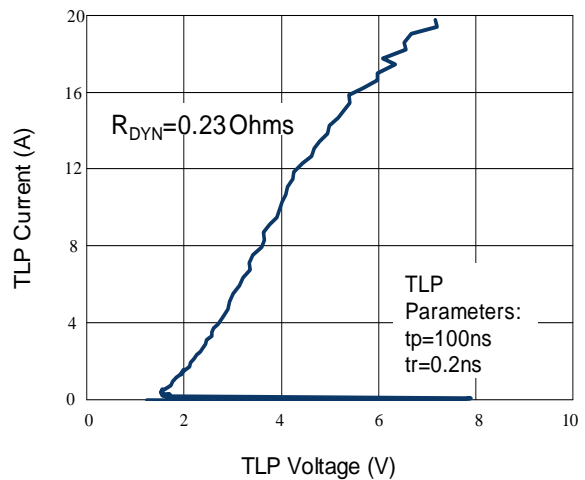
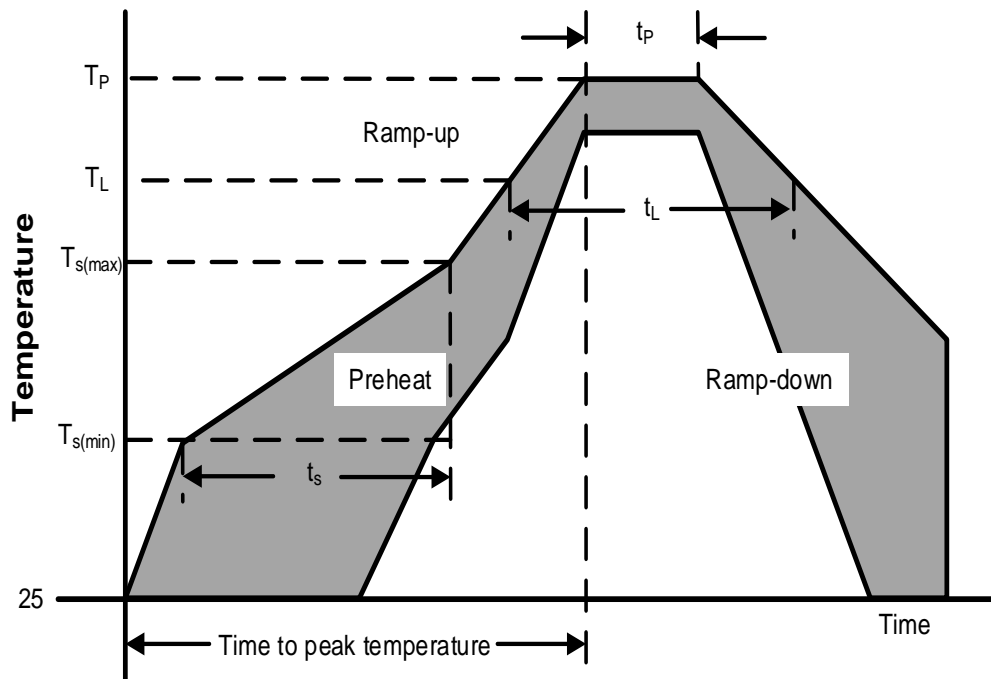

Figure 6: TLP I-V Curve



Soldering Parameters

Reflow Condition		Pb – Free assembly
Pre Heat	Temperature Min ( $T_{s(min)}$ )	150°C
	Temperature Max ( $T_{s(max)}$ )	200°C
	Time (min to max) ( $t_s$ )	60 – 190 secs
Average ramp up rate (Liquidus Temp) ( $T_L$ ) to peak		5°C/second max
$T_{s(max)}$ to $T_L$ — Ramp-up Rate		5°C/second max
Reflow	Temperature ( $T_L$ ) (Liquidus)	217°C
	Temperature ( $t_L$ )	60 – 150 seconds
Peak Temperature ( $T_P$ )		260+0/-5 °C
Time within actual peak Temperature ( $t_p$ )		20 – 40 seconds
Ramp-down Rate		5°C/second max
Time 25°C to peak Temperature ( $T_P$ )		8 minutes Max.
Do not exceed		280°C



Tape And Reel Information

Reel Dimensions

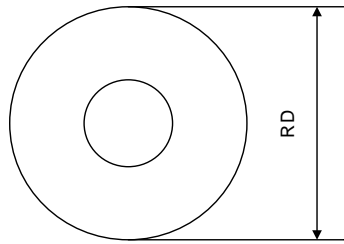

Tape Dimensions

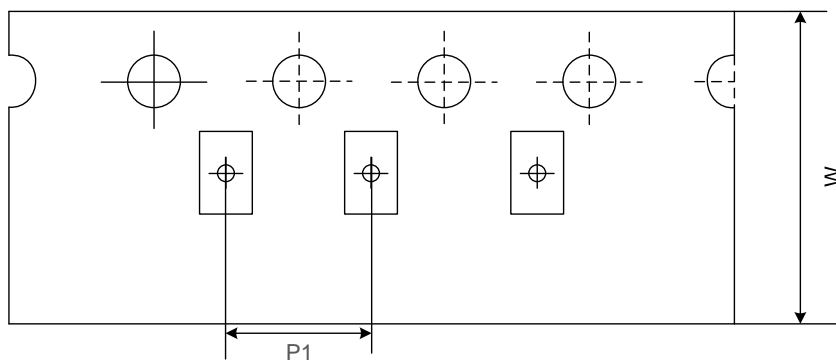

Quadrant Assignments For PIN1 Orientation In Tape

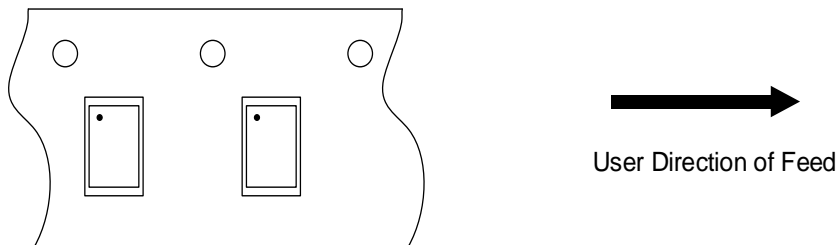

RD	Reel Dimensions	7 inch
W	Overall width of the carrier tape	8 mm
P1	Pitch between successive cavity centers	4mm

Outline Drawing –DFN2510-10L

DFN2.5x1-10L

DIM	MILLIMETERS		
	MIN	NOM	MAX
A	0.450	-	0.550
A1	0.025	0.050	0.075
D	2.450	2.500	2.550
E	0.950	1.000	1.050
b	0.150	0.200	0.250
b1	0.150	0.200	0.250
L	0.320	0.370	0.420
L1	0.000	0.030	0.060
R	0.100 REF		
e	0.500 BSC		

DIMENSIONS		
DIM	INCHES	MILLIMETERS
C	0.034	0.875
G	0.008	0.20
P	0.020	0.50
P1	0.039	1.00
X	0.010	0.25
X1	0.018	0.45
Y	0.027	0.675
Y1	0.061	1.55

**Notes:**  
Controlling Dimension: Millimeter.

Marking Codes

Part Number	WS6413KC
Marking Code	<div style="border: 1px solid black; display: inline-block; padding: 5px; margin-bottom: 5px;"> </div> <p>43K= Specific Device Code X=Month Code</p>

Package Information

Qty: 3k/Reel

CONTACT INFORMATION

No.1001, Shiwan (7) Road, Pudong District, Shanghai, P.R.China.201207

Tel: 86-21-68969993 Fax: 86-21-50757680 Email: [market@way-on.com](mailto:market@way-on.com)

WAYON website: <http://www.way-on.com>

For additional information, please contact your local Sales Representative.

**WAYON** ® is registered trademark of WAYON Corporation.

Specifications are subject to change without notice.  
The device characteristics and parameters in this data sheet can and do vary in different applications and actual device performance may vary over time.  
Users should verify actual device performance in their specific applications.