



WS5425K6

Transient Voltage Suppressor

Features

- Low operating voltage: 5V
- Ultra low capacitance
- Solid-state silicon-avalanche and active circuit triggering technology
- Up to four I/O Lines of Protection
- Low Leakage

IEC COMPATIBILITY (EN61000-4)

- IEC 61000-4-2 (ESD) $\pm 28\text{kV}$ (air), $\pm 25\text{kV}$ (contact)
- IEC 61000-4-4 (EFT) 40A (5/50ns)
- IEC 61000-4-5 (Lightning) 6A (8/20 μs)

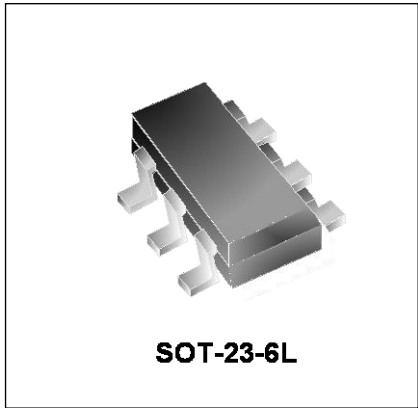

Mechanical Characteristics

- SOT-23-6L package
- Marking: Marking Code
- Packaging: Tape and Reel
- RoHS Compliant & HF
- Device meets MSL3 requirement

Applications

- Video/Graphics Card
- Digital Visual Interface (DVI)
- USB2.0 Power and Data lines protection
- Notebook and PC Computers
- Monitors and Flat Panel Displays

Circuit Diagram

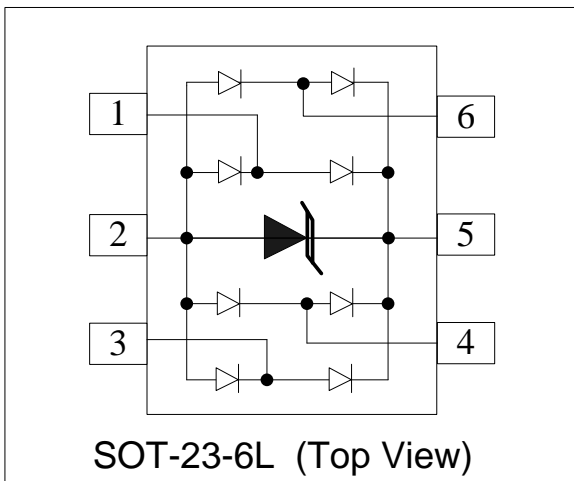

Schematic & PIN Configuration

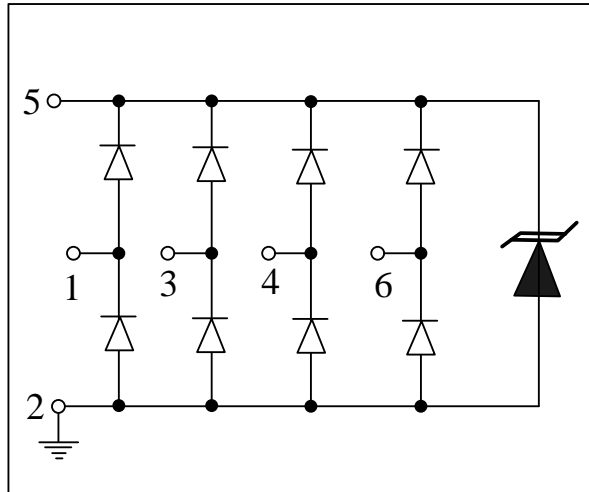

Absolute Maximum Rating

Rating	Symbol	Value	Units
Peak Pulse Power ($t_p = 8/20\mu s$)	P_{PP}	54	W
Peak Pulse Current ($t_p = 8/20\mu s$)	I_{PP}	6	A
Operating Temperature	T_J	-55 to + 125	°C
Storage Temperature	T_{STG}	-55 to +150	°C

Electrical Parameters

Symbol	Parameter
I_{PP}	Reverse Peak Pulse Current
V_C	Clamping Voltage @ I_{PP}
V_{RWM}	Reverse Stand-Off Voltage
I_R	Reverse Leakage Current @ V_{RWM}
V_{BR}	Breakdown Voltage @ I_T
I_T	Test Current
I_F	Forward Current
V_F	Forward Voltage @ I_F

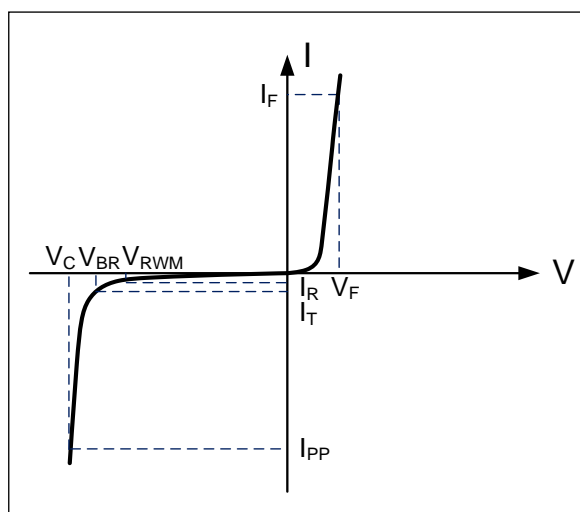

Electrical Characteristics (T=25°C unless otherwise noted)

WS5425K6						
Parameter	Symbol	Conditions	Minimum	Typical	Maximum	Units
Reverse Stand-Off Voltage	V_{RWM}				5	V
Reverse Breakdown Voltage	V_{BR}	$I_T = 1mA$	6			V
Reverse Leakage Current	I_R	$V_{RWM} = 5V$			500	nA
Forward Voltage	V_F	$I_T = 10mA$	0.6		1.2	V
Clamping Voltage	V_C	$I_{PP} = 6A, t_p = 8/20\mu s$ I/O pin to GND		7.5	9	V
Dynamic Resistance ^{1,2}	R_{DYN}	TLP=0.2/100ns I/O pin to GND		0.28		Ω
ESD Clamping Voltage ¹	V_C	$I_{PP} = 4A,$ $t_p = 0.2/100ns$ (TLP)		7.2		V
ESD Clamping Voltage ¹	V_C	$I_{PP} = 16A,$ $t_p = 0.2/100ns$ (TLP)		10.6		V
Junction Capacitance	C_j	$V_R = 2.5V, f = 1MHz$ I/O pin to GND		0.85	1.2	pF
		$V_R = 2.5V, f = 1MHz$ Between I/O pins		0.45	0.6	pF

Notes : 1、TLP Setting : $t_p = 100ns, t_r = 0.2ns, I_{TLP}$ and V_{TLP} sample window: $t_1 = 70ns$ to $t_2 = 90ns$.
 2、Dynamic resistance calculated from $I_{PP} = 4A$ to $I_{PP} = 16A$ using "Best Fit".

Typical Characteristics

Figure 1: Peak Pulse Power vs. Pulse Time

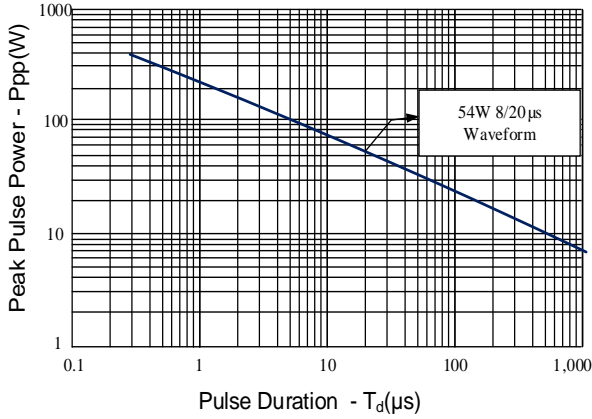

Figure 2: Power Derating Curve

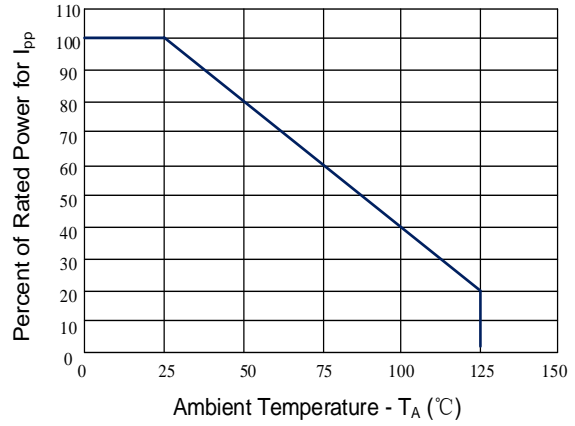

Figure 3: Clamping Voltage vs. Peak Pulse Current

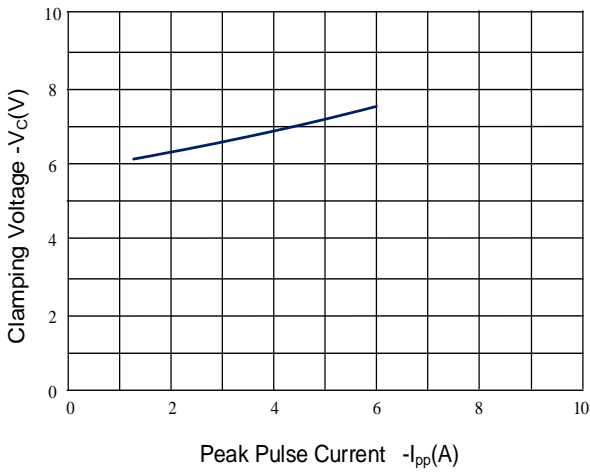

Figure 4: Normalized Junction Capacitance vs. Reverse Voltage

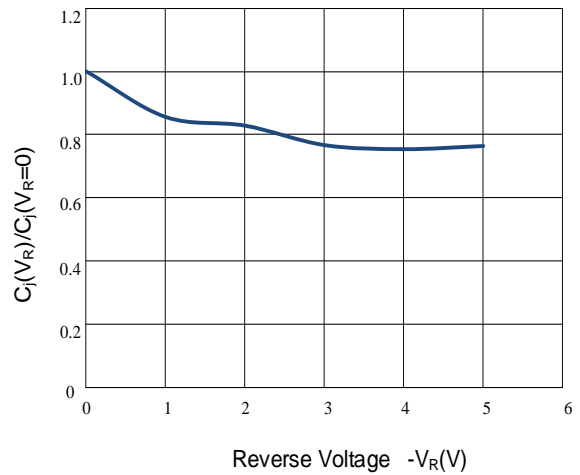

Figure 5: Pulse Waveform

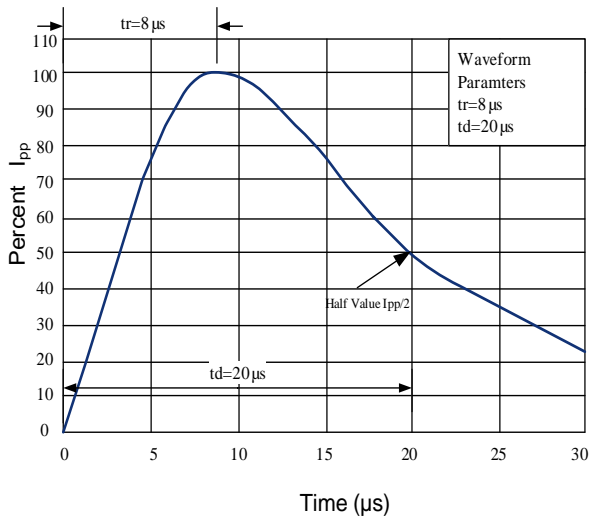
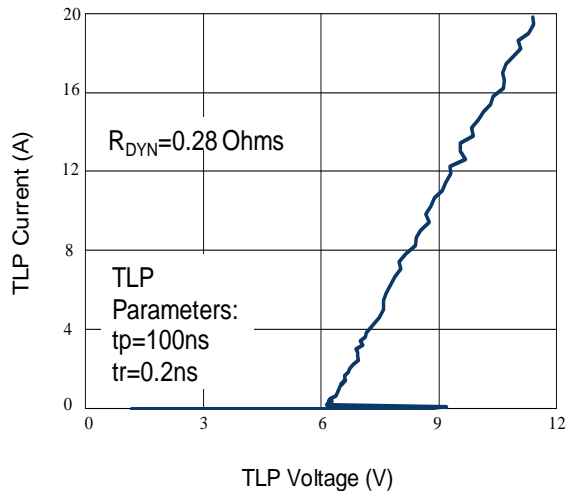
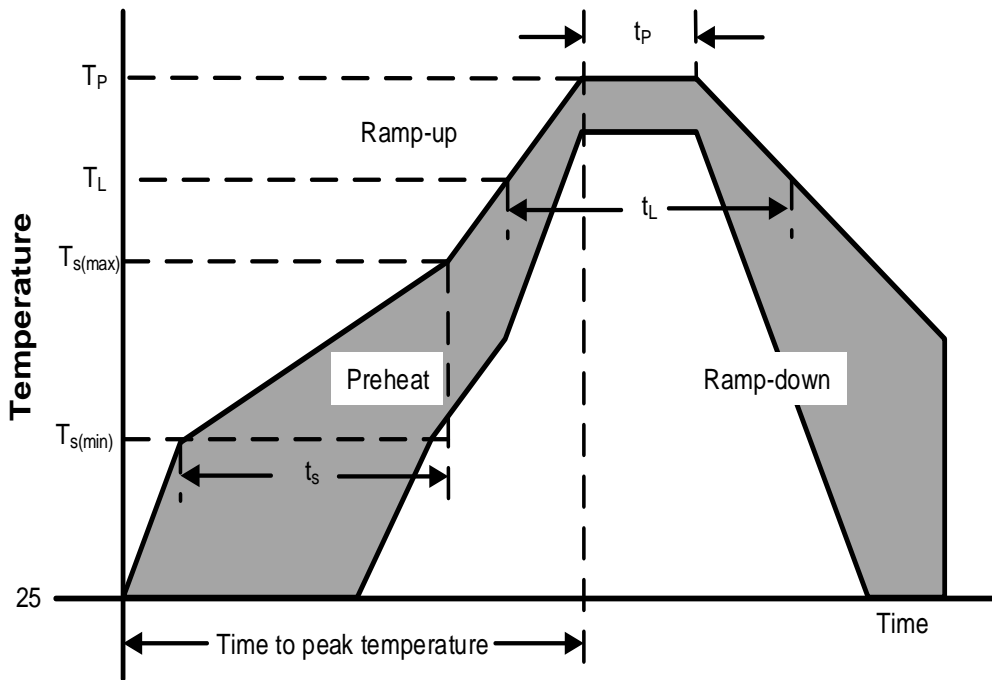

Figure 6: TLP I-V Curve



Soldering Parameters

Reflow Condition		Pb – Free assembly
Pre Heat	Temperature Min ($T_{s(min)}$)	150°C
	Temperature Max ($T_{s(max)}$)	200°C
	Time (min to max) (t_s)	60 – 190 secs
Average ramp up rate (Liquidus Temp) (T_L) to peak		5°C/second max
$T_{s(max)}$ to T_L — Ramp-up Rate		5°C/second max
Reflow	Temperature (T_L) (Liquidus)	217°C
	Temperature (t_L)	60 – 150 seconds
Peak Temperature (T_P)		260+0/-5 °C
Time within actual peak Temperature (t_p)		20 – 40 seconds
Ramp-down Rate		5°C/second max
Time 25°C to peak Temperature (T_P)		8 minutes Max.
Do not exceed		280°C



TAPE AND REEL INFORMATION

Reel Dimensions

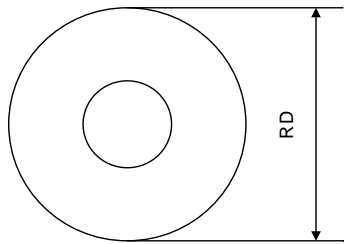

Tape Dimensions

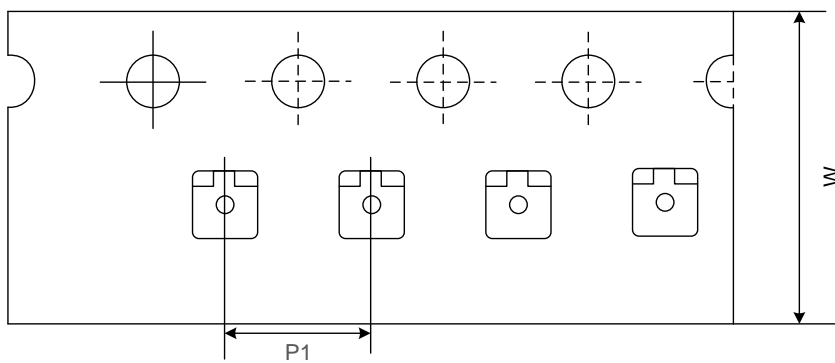

Quadrant Assignments For PIN1 Orientation In Tape

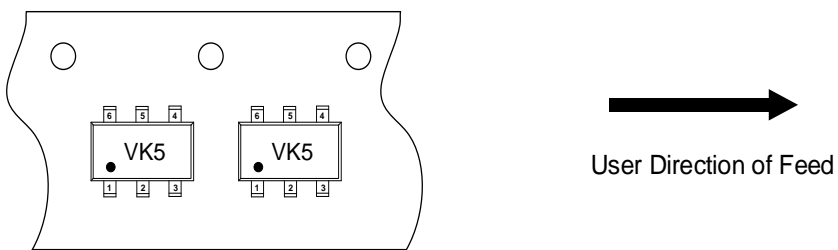

RD	Reel Dimensions	7 inch
W	Overall width of the carrier tape	8 mm
P1	Pitch between successive cavity centers	4mm

Outline Drawing – SOT-23-6L

PACKAGE OUTLINE

SOT-23-6L

DIM	MILLIMETERS	
	MIN	MAX
A	0.90	1.45
A1	0.00	0.15
A2	0.90	1.30
b	0.35	0.50
c	0.08	0.20
D	2.80	3.02
E1	1.50	1.75
E	2.60	3.00
e	0.95 BSC	
e1	1.90 BSC	
L	0.35	0.60
L1	0.55	0.75
θ 1	0°	8°
N	6	

DIMENSIONS		
DIM	INCHES	MILLIMETERS
C	0.098	2.50
G	0.055	1.40
P	0.037	0.95
X	0.024	0.60
Y	0.043	1.10
Z	0.141	3.60

Notes:

Controlling Dimension: Millimeter.

Marking Codes

Part Number	WS5425K6
Marking Code	

Package Information

Qty: 3k/Reel

CONTACT INFORMATION

No.1001, Shiwan(7) Road, Pudong District, Shanghai, P.R.China.201207
 Tel: 86-21-68969993 Fax: 86-21-50757680 Email: market@way-on.com
 WAYON website: <http://www.way-on.com>

For additional information, please contact your local Sales Representative.

WAYON ® is registered trademark of WAYON Corporation.

Specifications are subject to change without notice.
 The device characteristics and parameters in this data sheet can and do vary in different applications and actual device performance may vary over time.
 Users should verify actual device performance in their specific applications.