

Features

- Complementary to WT3906T
- Small Package

Mechanical Characteristics

- SOT-523 Package
- Marking : Making Code
- RoHS Compliant

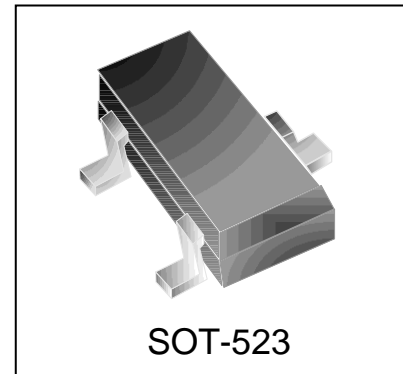

Schematic & PIN Configuration

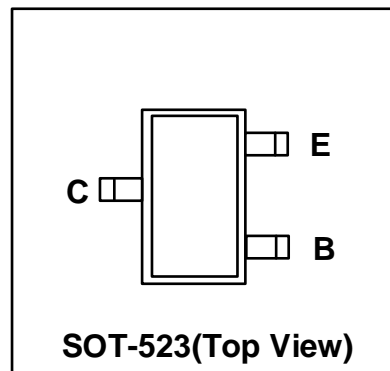
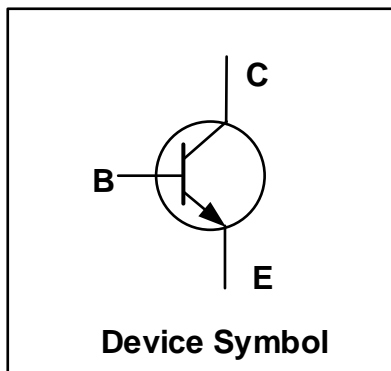

Absolute Maximum Rating

Parameter	Symbol	Value	Unit
Collector Base Voltage	V_{CBO}	60	V
Collector Emitter Voltage	V_{CEO}	40	V
Emitter Base Voltage	V_{EBO}	6	V
Collector Current	I_C	200	mA
Collector Power Dissipation	P_C	150	mW
Junction Temperature	T_j	150	°C
Storage Temperature	T_{stg}	-55 ~ 150	°C
Thermal Resistance, Junction to Ambient	$R_{\theta JA}$	833	°C/W

Electrical Characteristics (Ta=25°C unless otherwise noted)

Parameter	Symbol	Test Conditions	Min.	Typ.	Max.	Unit
Collector-Base Breakdown Voltage	$V_{(BR)CBO}$	$I_C = 10\mu A, I_E = 0$	60	-	-	V
Collector-Emitter Breakdown Voltage	$V_{(BR)CEO}$	$I_C = 1mA, I_B = 0$	40	-	-	V
Emitter-Base Breakdown Voltage	$V_{(BR)EBO}$	$I_E = 10\mu A, I_C = 0$	6	-	-	V
Collector Cut-off Current	I_{CEX}	$V_{CE} = 30V, V_{EB(off)} = 3V$	-	-	50	nA
Emitter Cut-off Current	I_{EBO}	$V_{EB} = 5V, I_C = 0$	-	-	100	nA
DC Current Gain	$h_{FE(1)}$	$V_{CE} = 1V, I_C = 0.1mA$	40	-	-	-
	$h_{FE(2)}$	$V_{CE} = 1V, I_C = 1mA$	70	-	-	-
	$h_{FE(3)}$	$V_{CE} = 1V, I_C = 10mA$	100	-	300	-
	$h_{FE(4)}$	$V_{CE} = 1V, I_C = 50mA$	60	-	-	-
Collector-Emitter Saturation Voltage	$V_{CE(sat)}$	$I_C = 10mA, I_B = 1mA$	-	-	0.2	V
		$I_C = 50mA, I_B = 5mA$	-	-	0.3	V
Base-Emitter Saturation Voltage	$V_{BE(sat)}$	$I_C = 10mA, I_B = 1mA$	0.65	-	0.85	V
		$I_C = 50mA, I_B = 5mA$	-	-	0.95	V
Transition Frequency	f_T	$V_{CE} = 20V, I_C = 10mA, f = 100MHz$	300	-	-	MHz
Collector Output Capacitance	C_{ob}	$V_{CB} = 5V, I_E = 0, f = 1MHz$	-	-	4	pF
Base Input Capacitance	C_{ib}	$V_{EB} = 0.5V, I_C = 0, f = 1MHz$	-	-	8	pF
Delay Time	t_d	$V_{CC} = 3V, V_{BE(off)} = -0.5V, I_C = 10mA, I_{B1} = 1mA$	-	-	35	ns
Rise Time	t_r	$V_{CC} = 3V, V_{BE(off)} = -0.5V, I_C = 10mA, I_{B1} = 1mA$	-	-	35	ns
Storage Time	t_s	$V_{CC} = 3V, I_C = 10mA, I_{B1} = I_{B2} = 1mA$	-	-	200	ns
Fall Time	t_f	$V_{CC} = 3V, I_C = 10mA, I_{B1} = I_{B2} = 1mA$	-	-	50	ns

Typical Characteristics

Figure 1. Static Characteristics

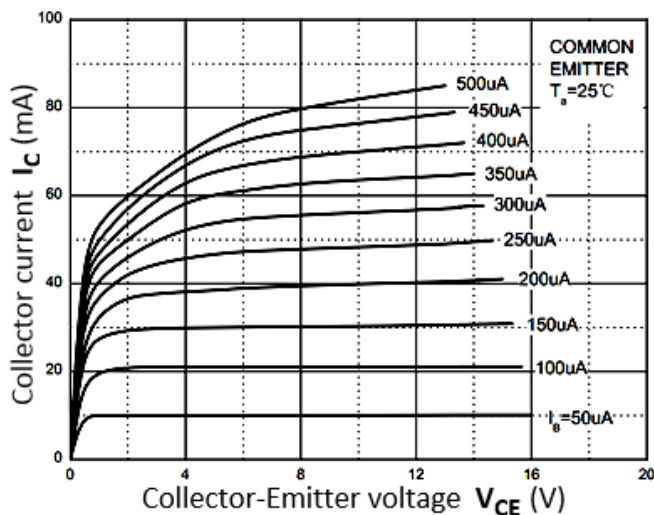

Figure 2. h_{FE} vs. I_C

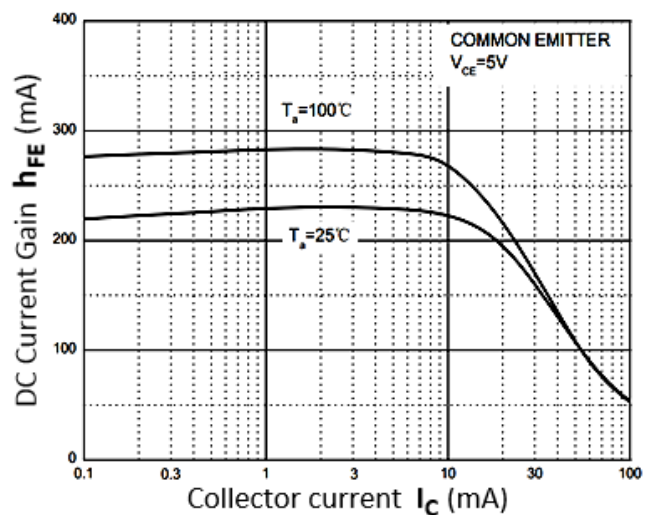

Figure 3. $V_{BE(sat)}$ vs. I_C

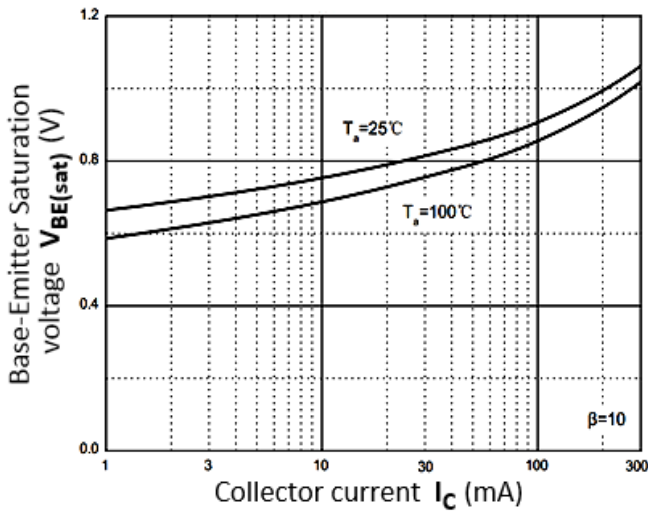

Figure 4. $V_{CE(sat)}$ vs. I_C

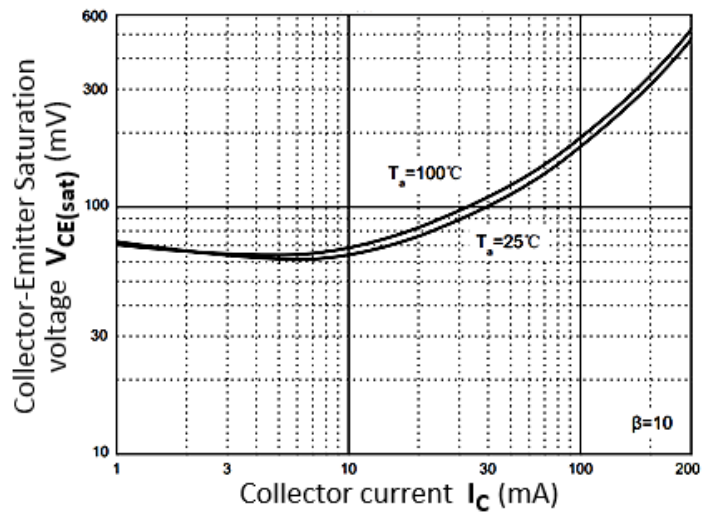

Figure 5. I_C vs. V_{BE}

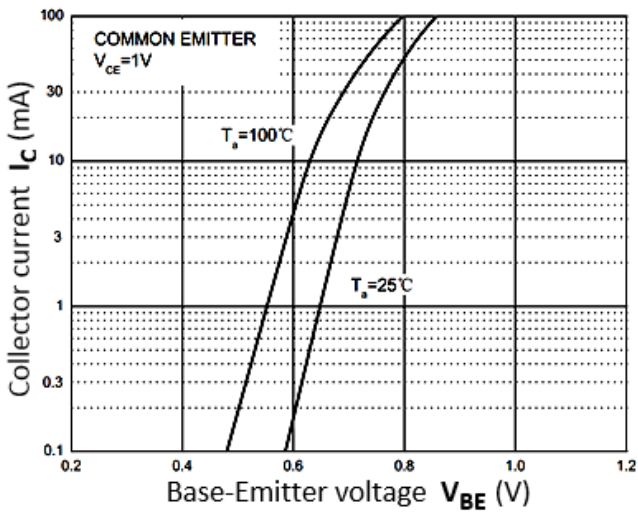

Figure 6. C_{ob} / C_{ib} vs. V_{CB} / V_{EB}

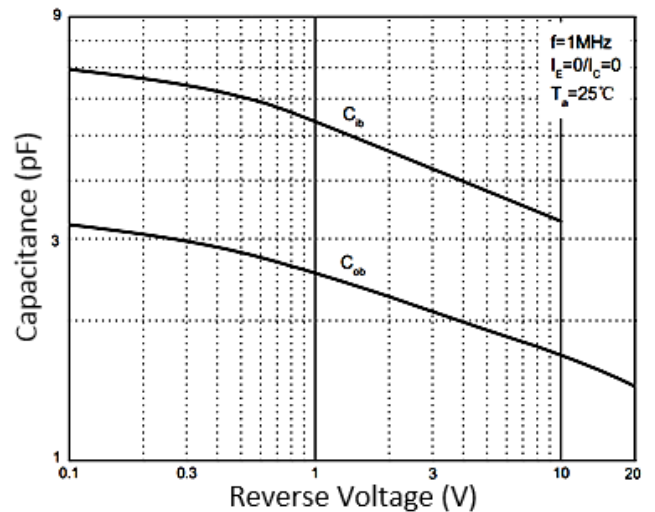

Figure 7. f_T vs. I_C

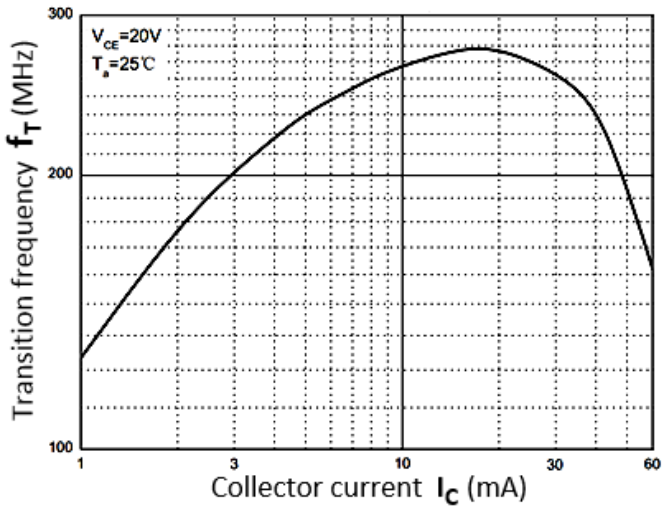
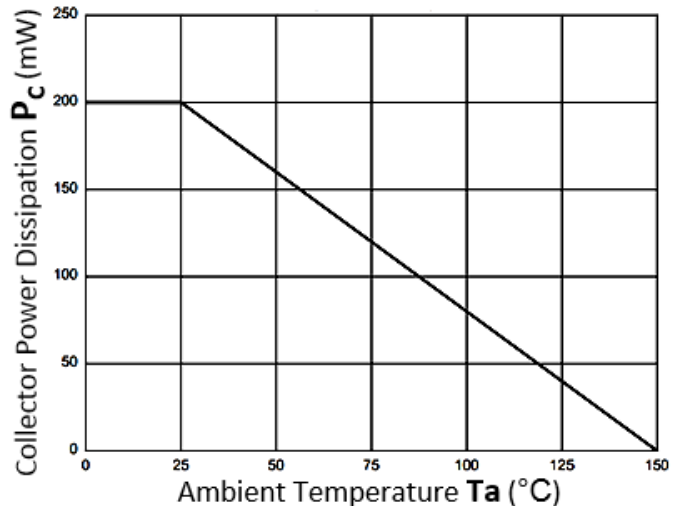

Figure 8. P_C vs. T_a



Outline Drawing – SOT-523

PACKAGE OUTLINE

SOT-523

DIMENSIONS				
SYMBOL	MILLIMETER		INCHES	
	MIN	MAX	MIN	MAX
A	0.700	0.900	0.028	0.035
A1	0.000	0.100	0.000	0.004
A2	0.700	0.800	0.028	0.031
b1	0.150	0.250	0.006	0.010
b2	0.250	0.325	0.010	0.013
c	0.100	0.200	0.004	0.008
D	1.500	1.700	0.059	0.067
E	0.700	0.900	0.028	0.035
E1	1.450	1.750	0.057	0.069
e	0.500TYP.		0.020TYP.	
e1	0.900	1.100	0.035	0.043
L	0.400REF.		0.016REF.	
L1	0.26	0.46	0.01	0.018
θ	0	8°	0	8°

DIMENSIONS		
DIM	INCHES	MILLIMETERS
C	.055	1.40
P	.039	1.00
P1	.020	0.400REF.50
G	.024	0.60
X	.016	0.40
Y	.031	0..80
Z	.087	2.20

Notes

1. Dimensioning and tolerances per ANSI Y14.5M, 1985.
2. Controlling Dimension: Inches
3. Pin 3 is the cathode (Unidirectional Only).
4. Dimensions are exclusive of mold flash and metal burrs.

Marking Codes

Part Number	WT3904T
Marking Code	

Package Information

Qty: 3k/Reel

CONTACT INFORMATION

No.1001, Shiwan (7) Road, Pudong District, Shanghai, P.R.China.201207
 Tel: 86-21-68969993 Fax: 86-21-50757680 Email: market@way-on.com
 WAYON website: <http://www.way-on.com>
 For additional information, please contact your local Sales Representative.

WAYON® is registered trademark of Wayon Corporation.

*Specifications are subject to change without notice.
 The device characteristics and parameters in this data sheet can and do vary in different applications and actual device performance may vary over time.
 Users should verify actual device performance in their specific applications.*