

NPN Silicon Transistor

Features

- Complementary to WT3906F
- Single General-Purpose Switching Transistor

Mechanical Characteristics

- DFN1006-3L Package
- Marking : Making Code
- RoHS Compliant

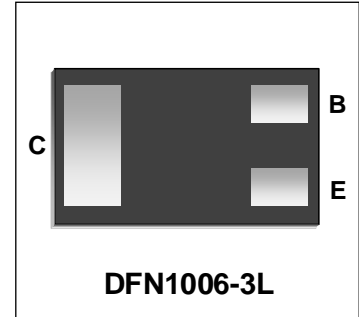

Schematic & PIN Configuration

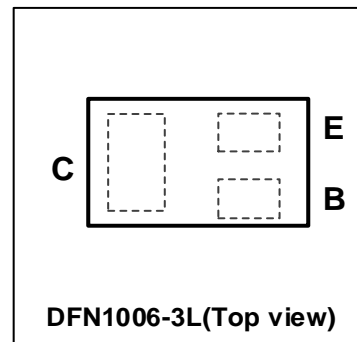
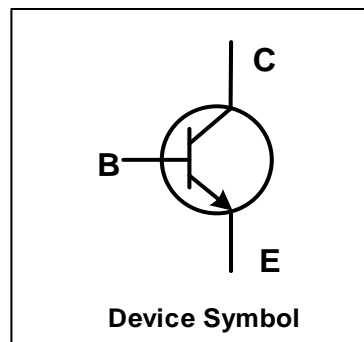

Absolute Maximum Rating

Parameter	Symbol	Value	Unit
Collector Base Voltage	V_{CBO}	60	V
Collector Emitter Voltage	V_{CEO}	40	V
Emitter Base Voltage	V_{EBO}	6	V
Collector Current	I_C	200	mA
Collector Power Dissipation ¹	P_C	100	mW
Collector Power Dissipation ²		590	
Junction Temperature	T_j	150	°C
Storage Temperature	T_{stg}	-55 ~ 150	°C
Thermal Resistance from Junction to Ambient ¹	$R_{\theta JA}$	1250	°C/W
Thermal Resistance from Junction to Ambient ²		212	

Note:

1. Device mounted on an FR4 PCB, single-sided copper, tin-plated and standard footprint.
2. Device mounted on an FR4 PCB, single-sided copper, tin-plated, mounting pad for collector 1cm².

Electrical Characteristics (T_{amb}=25°C unless otherwise noted)

Parameter	Symbol	Test Conditions	Min.	Typ.	Max.	Unit
Collector-Base Breakdown Voltage	V _{(BR)CBO}	I _C = 10μA, I _E = 0	60	-	-	V
Collector-Emitter Breakdown Voltage	V _{(BR)CEO}	I _C = 1mA, I _B = 0	40	-	-	V
Emitter-Base Breakdown Voltage	V _{(BR)EBO}	I _E = 10μA, I _C = 0	6	-	-	V
Collector Cut-off Current	I _{CBO}	V _{CB} = 60V, I _E = 0	-	-	100	nA
Collector Cut-off Current	I _{CEX}	V _{CE} = 30V, V _{EB(off)} = 3V	-	-	50	nA
Emitter Cut-off Current	I _{EBO}	V _{EB} = 5V, I _C = 0	-	-	100	nA
DC Current Gain	h _{FE(1)}	V _{CE} = 1V, I _C = 10mA	100	-	300	-
Collector-Emitter Saturation Voltage	V _{CE(sat)}	I _C = 50mA, I _B = 5mA	-	-	0.30	V
Base-Emitter Saturation Voltage	V _{BE(sat)}	I _C = 50mA, I _B = 5mA	-	-	0.95	V
Transition Frequency	f _T	V _{CE} = 20V, I _C = 10mA, f = 100MHz	300	-	-	MHz
Delay Time	t _d	V _{CC} = 3V, V _{BE(off)} = 0.5V, I _C = 10mA, I _{B1} = 1mA	-	30	-	ns
Rise Time	t _r		-	30	-	ns
Storage Time	t _s	V _{CC} = 3V, I _C = 10mA, I _{B1} = I _{B2} = 1mA	-	160	-	ns
Fall Time	t _f		-	40	-	ns

Typical Characteristics

Figure 1. Static Characteristics

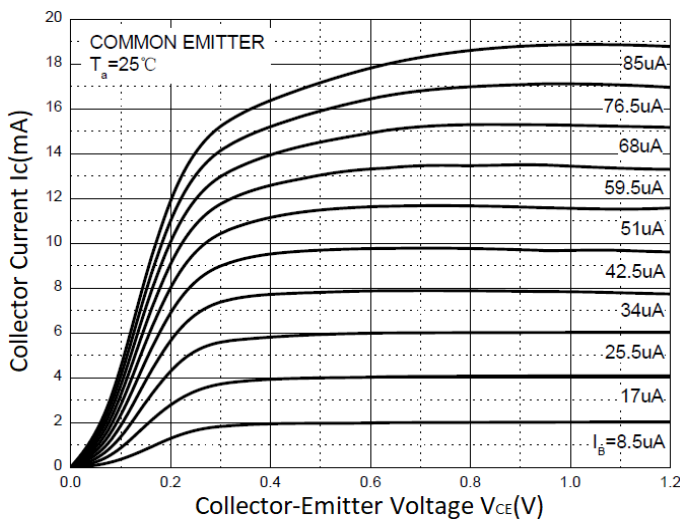

Figure 2. h_{FE} vs. I_C

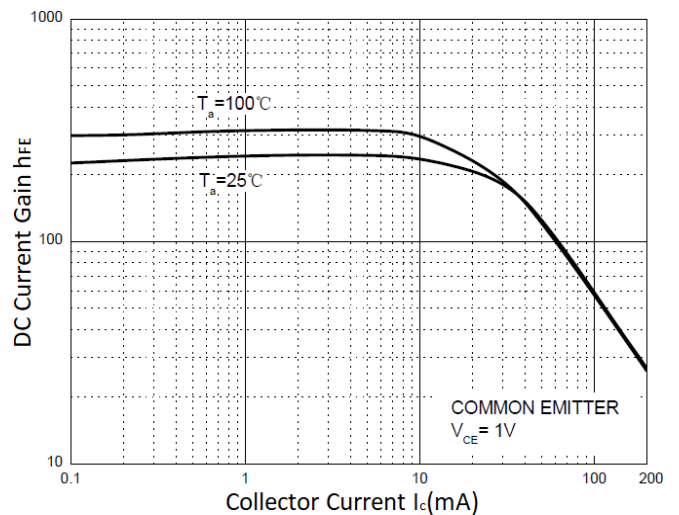

Figure 3. $V_{BE(sat)}$ vs. I_c

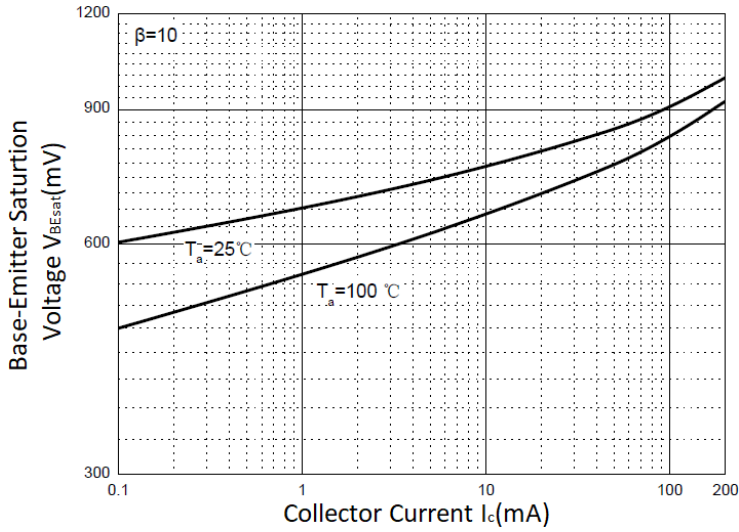

Figure 4. $V_{CE(sat)}$ vs. I_c

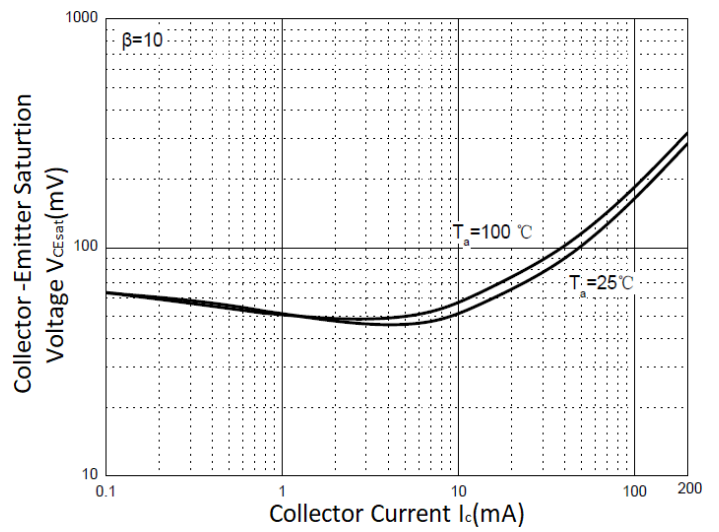

Figure 5. I_c vs. V_{BE}

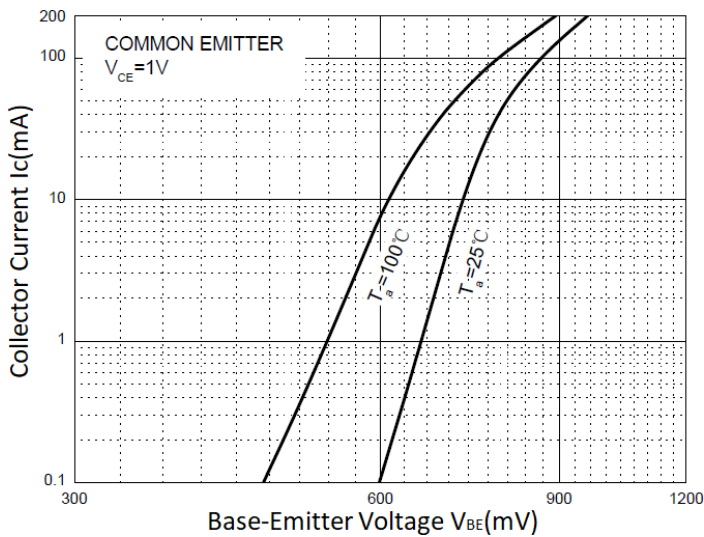

Figure 6. C_{ob} / C_{ib} vs. V_{CB} / V_{EB}

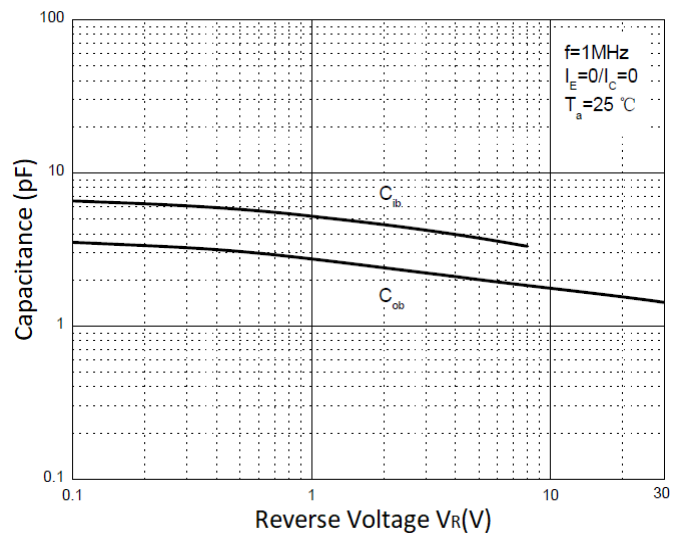

Figure 7. f_T vs. I_c

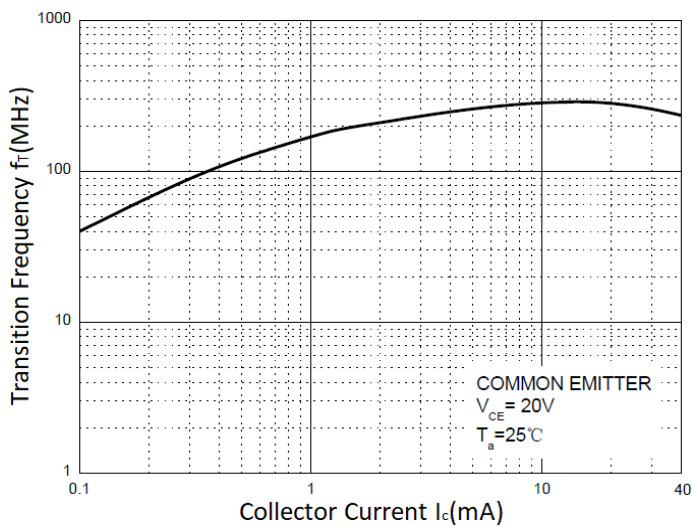
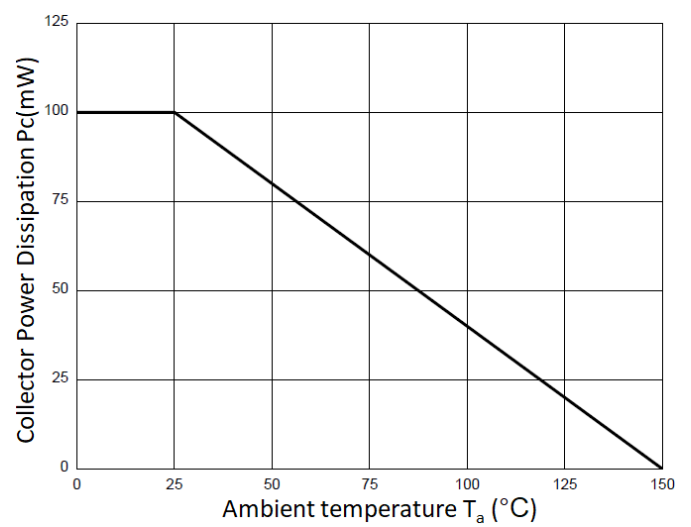

Figure 8. P_c vs. T_a



Outline Drawing – DFN1006-3L

PACKAGE OUTLINE

TOP VIEW

BOTTOM VIEW

DFN1006-3L

SYMBOL	MILLIMETER		
	MIN.	TYP.	MAX.
A	0.45	0.50	0.55
A1	0.00	-	0.05
b	0.40	0.50	0.60
b1	0.10	0.15	0.20
D	0.95	1.00	1.05
e	0.65BSC		
E	0.55	0.60	0.65
E1	0.19BSC		
L	0.20	0.25	0.30

Land Pattern

Marking Codes

Part Number	WT3904F
Marking Code	

Package Information

Qty: 10k/Reel

CONTACT INFORMATION

No.1001, Shiwan (7) Road, Pudong District, Shanghai, P.R.China.201207

Tel: 86-21-68969993 Fax: 86-21-50757680 Email: market@way-on.com

WAYON website: <http://www.way-on.com>

For additional information, please contact your local Sales Representative.

WAYON ® is registered trademark of Wayon Corporation.

Specifications are subject to change without notice.
The device characteristics and parameters in this data sheet can and do vary in different applications and actual device performance may vary over time.
Users should verify actual device performance in their specific applications.