

## Thyristor Programmable Overvoltage Protector

### Features

- Dual programmable transient suppressor.
- Wide negative firing voltage range:  
 $V_{GKRM} = -167V$  max.
- Low dynamic switching voltage:  
 $V_{FRM}$  and  $V_{GK(BO)}$
- Low gate triggering current:  
 $I_{GT} = 5mA$  max
- Peak pulse current:  
 $I_{PP} = 30A$  for 10/1000 $\mu s$  surge
- Holding current:  
 $I_H = 150mA$  min.

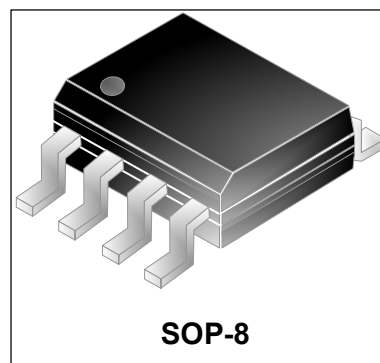

### Description

This device has been especially designed to protect monolithic subscriber line card interfaces (SLICs) against transient over-voltages. Positive overloads are clipped with four diodes. Negative surges are suppressed by four thyristors, their breakdown voltage being referenced to  $-V_{BAT}$  through the gate. This component presents a very low gate triggering current ( $I_{GT}$ ) in order to reduce the current consumption on printed circuit board during the firing phase. A particular attention has been given to the internal wire bonding. The configuration ensures reliable protection, eliminating the overvoltage introduced by the parasitic inductances of the wiring ( $Ldi/dt$ ), especially for very fast transients.

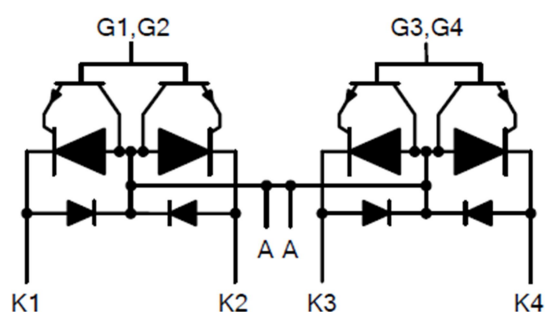

SOP-8 Package(Top View)	
Pin#	Description
1,4,5,8	Connect to subscriber lines(Tip or Ring)
2,3	Connect to battery
6,7	Connect ground

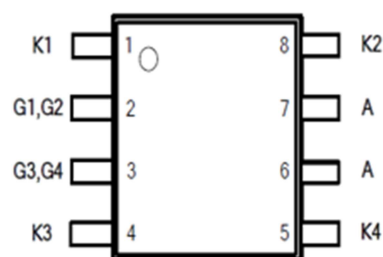

### Complies with The Following Standards

YD/T 950-1998  
ITU-T K.20, K21  
FCC part 68  
GR-1089-CORE

Voltage waveform ( $\mu\text{s}$ )	Current waveform ( $\mu\text{s}$ )	Required peak current (A)
2/10 $\mu\text{s}$	2/10 $\mu\text{s}$	120
10/700 $\mu\text{s}$	5/310 $\mu\text{s}$	40
10/1000 $\mu\text{s}$	10/1000 $\mu\text{s}$	30

### Absolute Maximum Ratings

Symbol	Parameter	Value	Unit
$I_{PP}$	Non-repetitive peak on-state pulse current		
	10/1000 $\mu\text{s}$	30	A
	5/310 $\mu\text{s}$	40	
	2/10 $\mu\text{s}$	120	
$I_{TSM}$	Non repetitive surge peak on-state current (sinusoidal), 60Hz 900s	0.5	A
$V_{DRM}$	Maximum voltage LINE/GROUND	-170	V
$V_{GKRM}$	Maximum voltage GATE/LINE	-167	
$T_{STG}$	Storage temperature range	-40~150	$^{\circ}\text{C}$
$T_J$	Junction temperature	-40~150	
$T_L$	Maximum lead temperature for soldering during 10S	260	
$R_{\theta JA}$	Junction to ambient	120	$^{\circ}\text{C/W}$

### Electrical Characteristics ( $T_A=25^{\circ}\text{C}$ )

Symbol	Parameter
$I_D$	Off-state current
$I_H$	Holding current
$V_{(BO)}$	Breakdown voltage
$V_F$	Forward voltage
$V_{FRM}$	Peak forward recovery voltage
$V_{GK(BO)}$	Gate-cathode impulse breakdown voltage
$I_{GKS}$	Gate reverse current
$I_{GT}$	Gate trigger current
$V_{GT}$	Gate-cathode trigger voltage
$C_{KA}$	Cathode-anode off-state capacitance

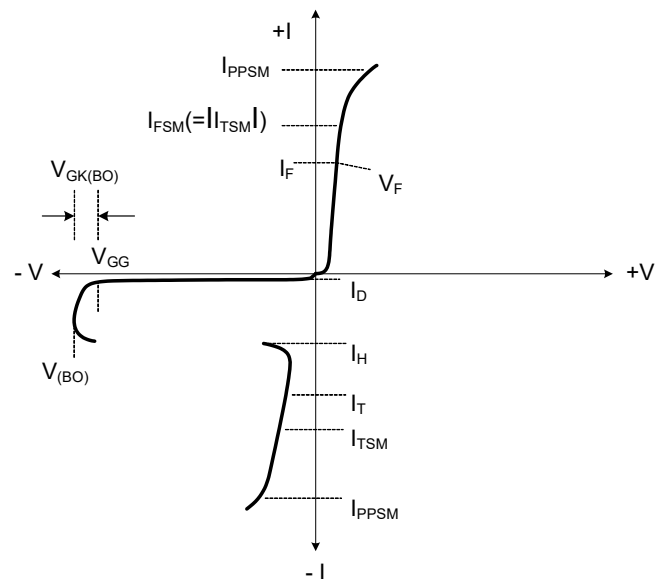

Figure 1. Voltage-Current Characteristic  
Unless Otherwise Noted, All Voltages are Referenced to the Anode

### Parameters Related to The Diode ( $T_A=25^{\circ}\text{C}$ )

Parameter	Test conditions	Min.	Typ.	Max.	Unit.
$V_F$ forward voltage	$I_F=5\text{A}$ , $t_w=200\mu\text{s}$			3	V
$V_{FRM}$ peak forward recovery voltage	2/10 $\mu\text{s}$ , $I_F=40\text{A}$ , $R_s=55\Omega$ , $V_{GG}=-100\text{V}$ , $C_G=220\text{nF}$		10		V

### Parameters Related to The Protection Thyristor (T<sub>A</sub>=25°C)

Parameter	Test conditions	Min.	Typ.	Max.	Unit.
I <sub>D</sub> off-state current	V <sub>D</sub> =-170V, V <sub>GK</sub> =0	T <sub>J</sub> =25°C		-5	μA
		T <sub>J</sub> =85°C		-50	μA
V <sub>BO</sub> breakover voltage	2/10μs, I <sub>T</sub> =-40A, R <sub>s</sub> =55Ω, V <sub>GG</sub> =-100V, C <sub>G</sub> =220nF			-112	V
I <sub>H</sub> holding current	I <sub>T</sub> =-1A, di/dt=1A/ms, V <sub>GG</sub> =-100V	-150			mA
I <sub>GKS</sub> gate reverse current	V <sub>GG</sub> =V <sub>GK</sub> =-167V, V <sub>KA</sub> =0	T <sub>J</sub> =25°C		-5	μA
		T <sub>J</sub> =85°C		-50	μA
I <sub>GT</sub> gate trigger current	I <sub>T</sub> =-3A, t <sub>p</sub> (g)≥20μs, V <sub>GG</sub> =-100V			5	mA
V <sub>GT</sub> gate trigger voltage	I <sub>T</sub> =-3A, t <sub>p</sub> (g)≥20μs, V <sub>GG</sub> =-100V			2.5	V
C <sub>KA</sub> cathode-anode off-state capacitance	f=1MHz, V <sub>d</sub> =1V, I <sub>G</sub> =0	V <sub>D</sub> =-3V		100	pF
		V <sub>D</sub> =-48V		50	pF

### Soldering Parameters

Reflow Condition		
Pre Heat	Temperature Min (T <sub>s(min)</sub> )	150°C
	Temperature Max (T <sub>s(max)</sub> )	200°C
	Time (min to max) (t <sub>s</sub> )	60-190 s
Average ramp up rate (Liquidus Temp) (T <sub>L</sub> ) to peak		3°C/s max
Ts(max) to TL - Ramp-up Rate		3°C/s max
Reflow	Temperature (T <sub>L</sub> ) (Liquidus)	217°C
	Temperature (t <sub>L</sub> )	60-150 s
Peak Temperature (T <sub>P</sub> )		260 <sup>+0/-5</sup> °C
Time within actual peak Temperature (t <sub>p</sub> )		20-40 s
Ramp-down Rate		5°C/s max
Time 25°C to peak Temperature (T <sub>P</sub> )		8 minutes Max.
Do not exceed		260°C

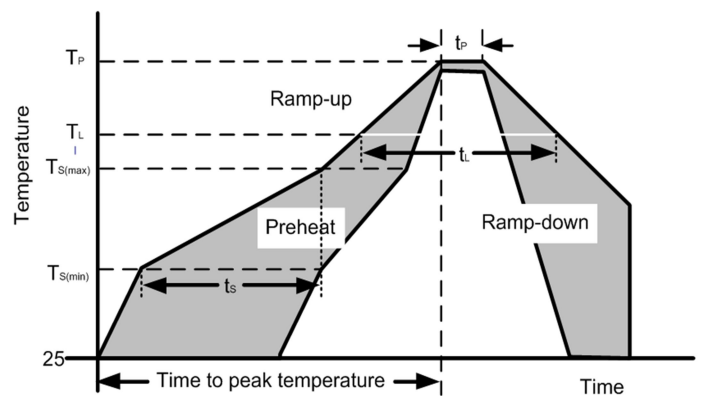

### Product Dimensions

Ref. (mm)	Min.	Typ.	Max.
A	1.35		1.75
A1	0.10		0.25
A2	1.35		1.65
b	0.33		0.51
c	0.17		0.25
D	4.80		5.00
E	5.80		6.20
e		1.27	
E1	3.80		4.00
L	0.40		1.27
Θ	0°		8°

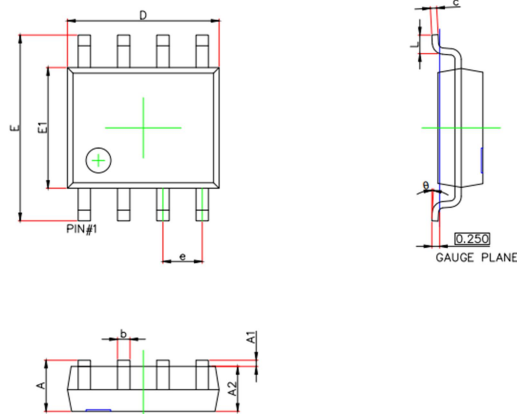

### Solder pad layout

DIMENSIONS		
DIM	INCHES	MILLIMETERS
C	0.205	5.21
G	0.118	3.00
P	0.050	1.27
X	0.024	0.61
Y	0.087	2.21
Z	0.291	7.39

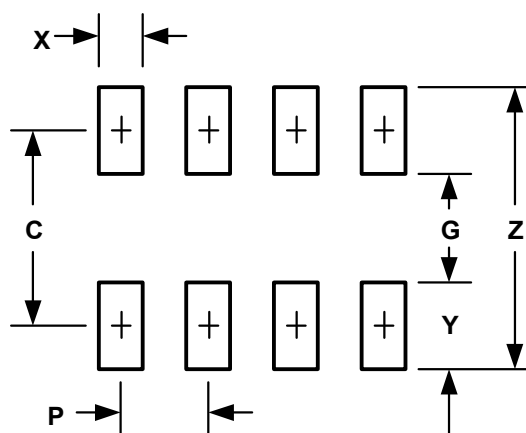

### Part Numbering System and Marking

W EOS 6 1089 -17Q

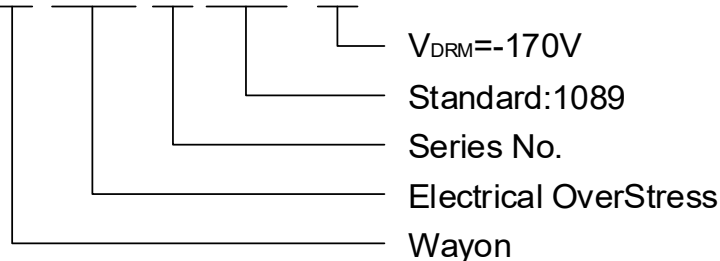

MARKING:

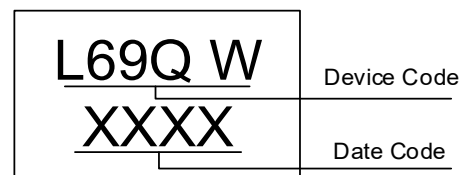

### Package Information

Package Type	Description	Quantity (pcs)
SOP8	Tape & Reel	4000

### Contact Information

No.1001, Shiwan(7) Road, Pudong District, Shanghai, P.R.China.201207

Tel: 021-68969993 Fax: 86-21-50757680 Email: market@way-on.com

WAYON website: <http://www.way-on.com>

For additional information, please contact your local Sales Representative.

**WAYON**® is registered trademarks of Wayon Corporation.

*Specifications are subject to change without notice.  
The device characteristics and parameters in this data sheet can and do vary in different applications and actual device performance may vary over time.  
Users should verify actual device performance in their specific applications.*