

Over-Voltage Protection IC

General Description

WP1432 can disconnect the systems from its output pin (OUT) in case wrong input operating conditions are detected.

The system is positive overvoltage protected up to 36V. The internal overvoltage thresholds (OVLO) is 6.1V and internal overcurrent thresholds (OCP) is 2.5A, WP1432 also has internal over temperature protect (OTP) function and it can monitor chip temperature to protect the device.

The device is packaged in advanced full-Green Packaging (SOT23-6L).

Applications

- Smartphones, Tablet PC
- HDD, Storage and Solid State Memory Devices
- Portable Media Devices, Laptop & MID
- SLR Digital Cameras
- GPS and Navigation Equipment
- Industrial Handheld and Enterprise Equipment

Features

- Typical R_{ON} : 110m Ω N-Channel MOSFET@5V/1A
- V_{IN} Operating Range: 3V to 36V
- Internal Overvoltage Lockout: 6.1V(TYP)
- Internal Overcurrent Lockout: 2.5A(MIN)
- Overvoltage-Protection Response Time: <500ns
- Startup Debounce Time: 16ms(TYP)
- Typical Output Power on Time:16.3ms(TYP)
- Internal Thermal-Shutdown Protection
- ESD Protected: Human Body Model: JESD22-A114 (All pins) \pm 2KV
- SOT23-6L Package

Typical Application

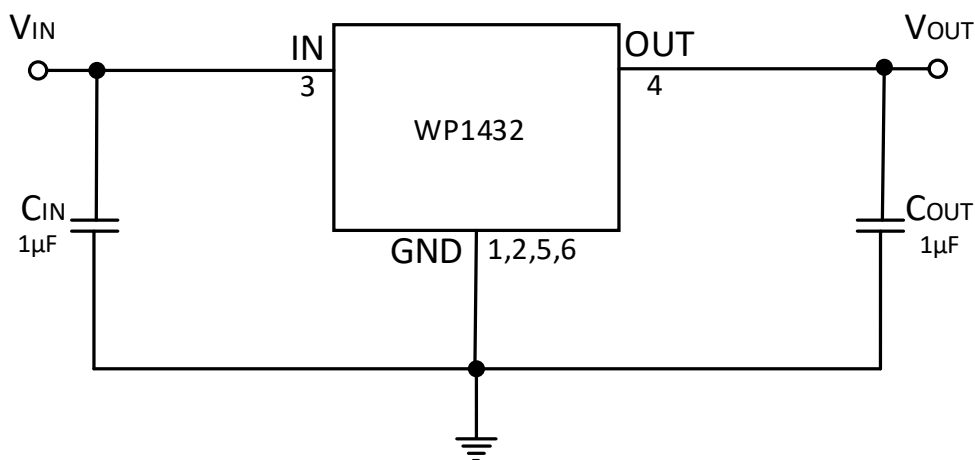

*NOTE: This electric circuit only supplies for reference.

Pin Configuration

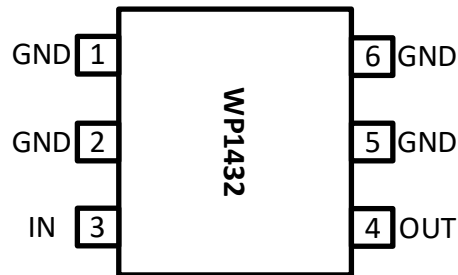

(TOP VIEW)

Pin Description

Pin Number	Pin Name	Description
1,2,5,6	GND	Ground. Connect GND pins together for proper operation.
3	IN	Voltage Input.
4	OUT	Voltage Output.

Absolute Maximum Ratings

SYMBOL	Parameter	MIN	MAX	Unit
V_{IN}	V_{IN} to GND	-0.3	36	V
V_{OUT}	V_{OUT} to GND	-0.3	28	V
I_{SW1}	Maximum Continuous Current of switch IN-OUT		2.5	A
I_{SW2}	Maximum Peak Current of switch IN-OUT(10ms)		4	A
PD	Power Dissipation at $T_A = +70^{\circ}C$		500	mW
T_{STG}	Storage Junction Temperature	-65	+150	$^{\circ}C$
T_A	Operating Temperature Range	-40	+85	$^{\circ}C$
T_{Store}	Soldering Temperature (reflow)		+260	$^{\circ}C$
T_J	Junction Temperature		+150	$^{\circ}C$

Electrical Characteristics

($T_A=25\text{ }^\circ\text{C}$, $V_{IN}=5\text{V}$, unless otherwise noted)

SYMBOL	Parameter	Test Condition	Min	Typ	Max	Unit
Basic Operation						
V_{IN}	Input Voltage		3		36	V
I_{IN}	V_{IN} Quiescent Current	$V_{IN}=5\text{V}$, OUT floating		110		μA
R_{ON}	On-Resistance of Switch IN-OUT	$V_{IN}=5\text{V}$, $I_{OUT}=1\text{A}$		110		$\text{m}\Omega$
V_{OVLO}	Overvoltage protect of V_{IN}	V_{IN} rise up	5.8	6.1	6.4	V
	Overvoltage protect hysteresis of V_{IN}			0.15		V
V_{UVLO_R}	Under Voltage Lockout Threshold			2.5		V
Over Temperature Protection (OTP)						
	Thermal Shutdown			155		$^\circ\text{C}$
	Thermal-shutdown Hysteresis			20		$^\circ\text{C}$
Input Over						
t_{DEB}	Debounce time	Time from $2.1\text{V} < V_{IN} < V_{OVLO}$ to $V_{OUT} = 10\%$ of V_{IN}		16		ms
t_{ON}	Switch Turn-on time	$R_L=100\Omega$, $C_L=22\mu\text{F}$, V_{OUT} from $0.1 \times V_{IN}$ to $0.9 \times V_{IN}$		0.3		ms
t_{ON_ALL}	Output power-on Time	Time from $2.1\text{V} < V_{IN} < V_{OVLO}$ to $V_{OUT}=90\%$ of V_{IN}		16.3		ms
$t_{OFF_RES}^{(1)}$	Switch turn-off response time	$V_{IN} > V_{OVLO}$ to V_{OUT} stop rising		100	500	ns
Dynamic Characteristics:see figure						
I_{OCP}	Overcurrent protect of I		2.5	3.1		A
I_{SHORT}				120		mA
t_{OCP}	OCP debounce time			30		ms
T_{REC_OCP}	OCP recovery time			1		s

Note:

(1)Guaranteed by characterization and design.

Timing Diagram

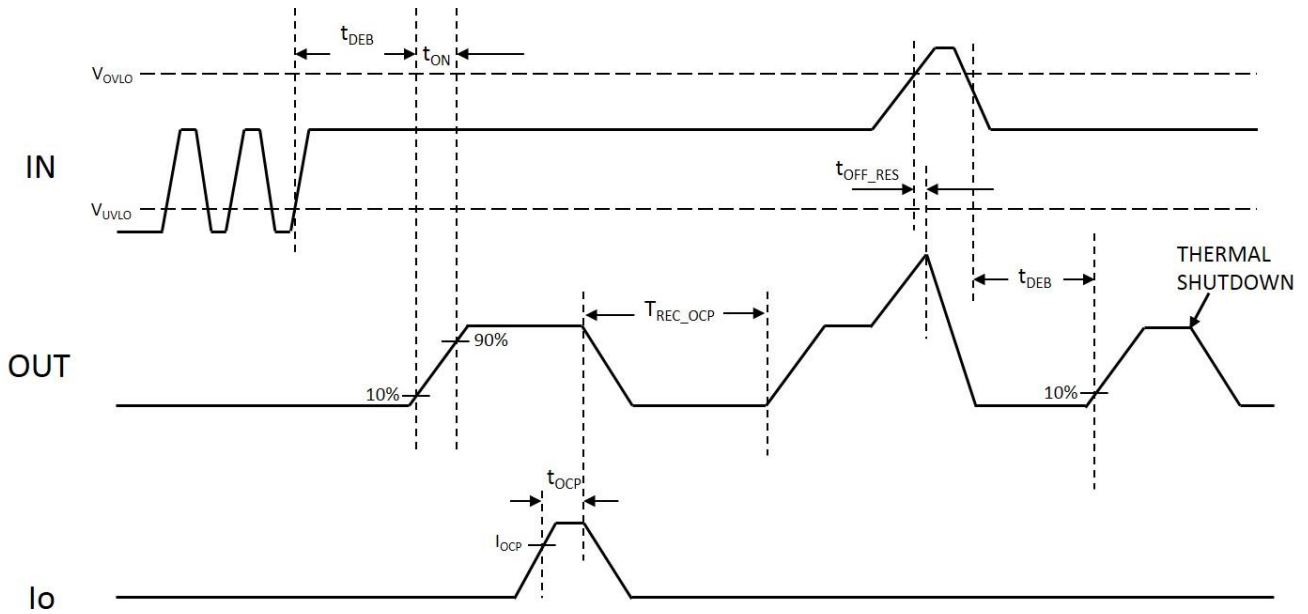

*NOTE: WAVEFORMS ARE NOT TO SCALE

Block Diagram

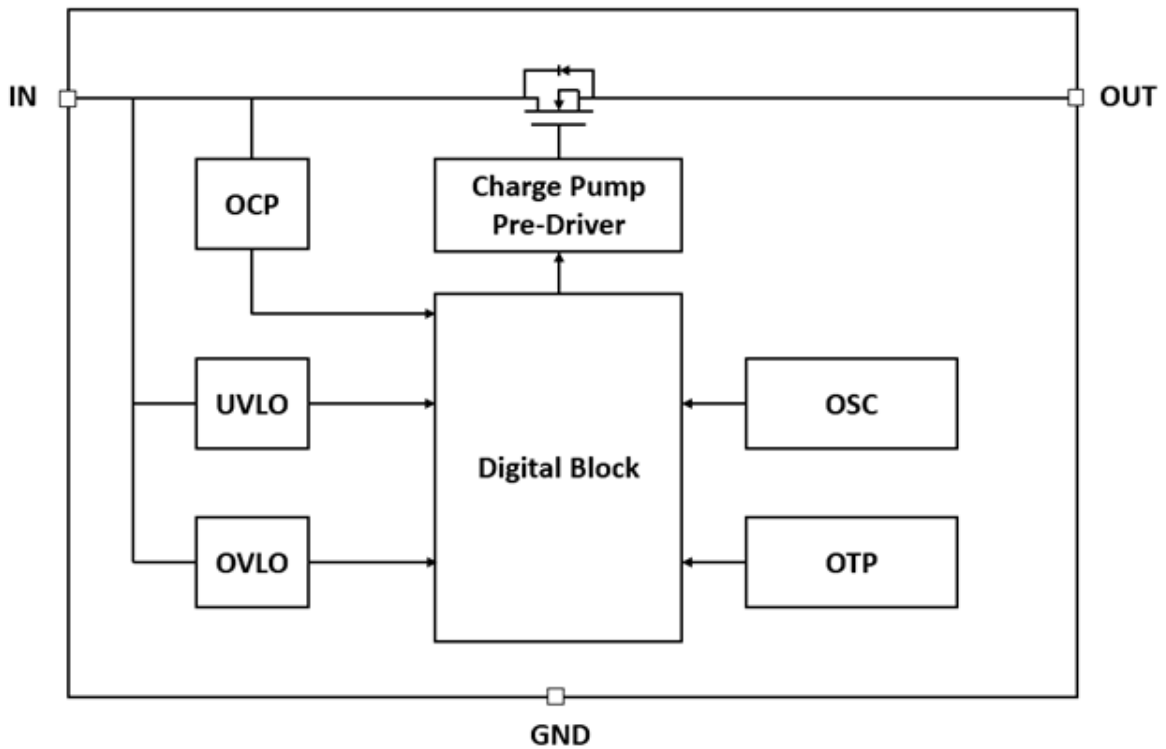

Functional Description

The OVP switch with overvoltage protection feature a low 110m Ω (TYP) on-resistance(RO_N) internal FET and protect low-voltage systems against voltage faults up to 36V_{DC}. If the input voltage(V_{IN}) exceeds 6.1V, or input current exceeds 2.5A, the internal FET is quickly turned off to prevent damage to the protected downstream components.

The internal FET turns off when the junction temperature exceeds +155°C (TYP). The device exits thermal shutdown after the junction temperature cools by 20°C (TYP).

Input Capacitor

To limit the voltage drop on the input supply caused by transient inrush current when the switch turns on into a discharged load capacitor or short-circuit, a capacitor 1 μ F or larger must be placed between the V_{IN} and GND pins.

Output Capacitor

A 1 μ F or larger capacitor should be placed between the OUT and GND pins.

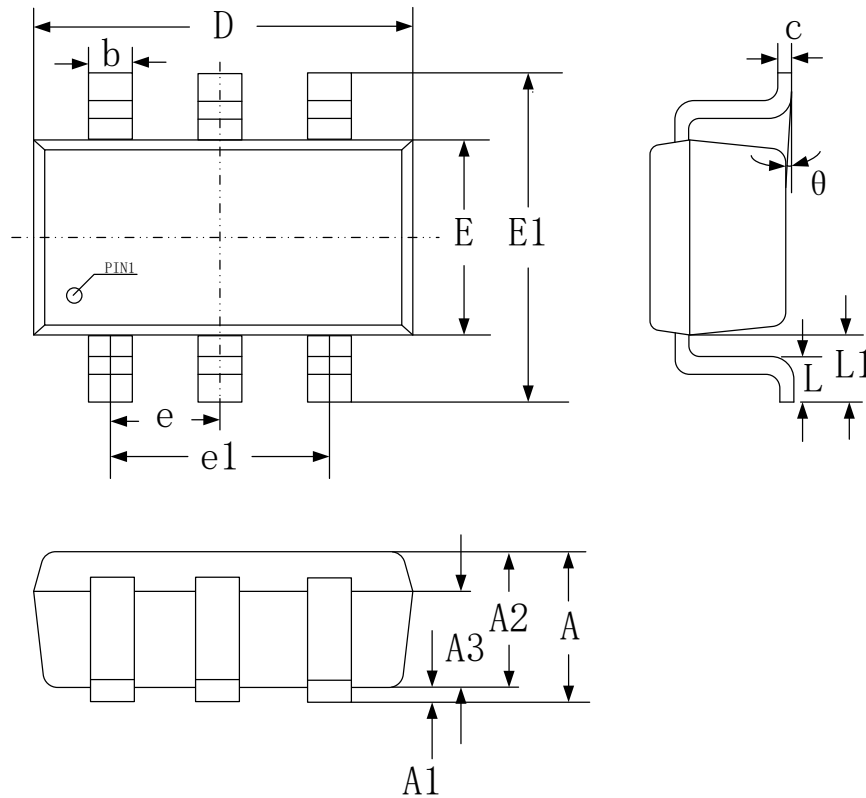
Package Information

SOT 23-6

SYMBOL	DIMENSIONS IN MILLIMETERS		
	MIN	NOM	MAX
A	-	-	1.25
A1	0.00	-	0.15
A2	1.00	1.10	1.20
A3	0.575	0.65	0.725
b	0.325	-	0.5
c	0.1	-	0.2
D	2.82	2.92	3.02
E	1.50	1.60	1.70
E1	2.60	2.80	3.00
e	0.925	0.95	0.975
e1	1.90 BSC		
L1	0.59 REF		
L	0.35	0.45	0.60
θ	0°		8°

Ordering Information

Part Number	Package	Packing Quantity	Marking
WP1432-A60R	SOT23-6L	3k/Reel	WP1430 XXXXX

Contact Information

No.1001, Shiwan(7) Road, Pudong District, Shanghai, P.R.China.201202

Tel: 86-21-68960674 Fax: 86-21-50757680 Email: market@way-on.com

WAYON website: <http://www.way-on.com>

For additional information, please contact your local Sales Representative.

 is registered trademark of Wayon Corporation.

Specifications are subject to change without notice.

The device characteristics and parameters in this data sheet can and do vary in different applications and actual device performance may vary over time

Users should verify actual device performance in their specific applications.