

PNP Silicon Transistor

Features

- Complementary to WT3904
- Epitaxial Planar Die Construction
- Ideal for Medium Power Amplification and Switching

Mechanical Characteristics

- SOT-23 Package
- Marking : Making Code
- RoHS Compliant & HF
- Device meets MSL3 requirement

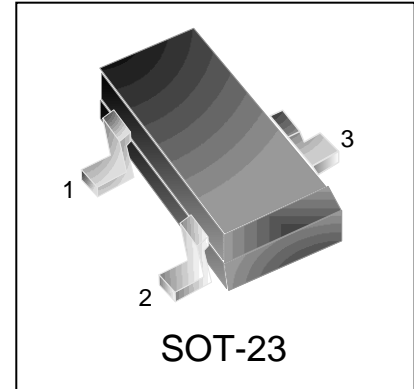

Schematic & PIN Configuration

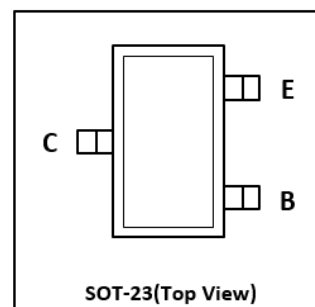
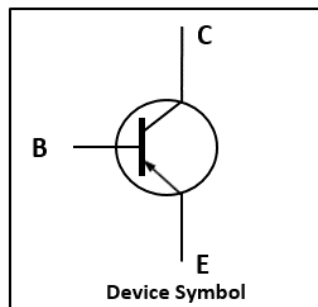

Absolute Maximum Rating

Parameter	Symbol	Value	Unit
Collector Base Voltage	V_{CBO}	-40	V
Collector Emitter Voltage	V_{CEO}	-40	V
Emitter Base Voltage	V_{EBO}	-6	V
Collector Current	I_C	-200	mA
Power Dissipation	P_D	350	mW
Junction Temperature	T_j	-55 ~ 150	°C
Storage Temperature	T_{stg}	-55 ~ 150	°C
Thermal Resistance, Junction to Ambient	$R_{\theta JA}$	357	°C/W
Thermal Resistance, Junction to Case	$R_{\theta JC}$	185	°C/W

Electrical Characteristics ($T_{amb}=25^{\circ}C$ unless otherwise specified)

Parameter	Symbol	Test Conditions	Min.	Typ.	Max.	Unit
Collector-base breakdown voltage	$V_{(BR)CBO}$	$I_C = -10\mu A, I_E = 0$	-40	-	-	V
Collector-emitter breakdown voltage	$V_{(BR)CEO}$	$I_C = -1mA, I_B = 0$	-40	-	-	V
Emitter-base breakdown voltage	$V_{(BR)EBO}$	$I_E = -10\mu A, I_C = 0$	-6	-	-	V
Collector cut-off current	I_{CBO}	$V_{CB} = -40V, I_E = 0$	-	-	-50	nA
Collector cut-off current	I_{CEX}	$V_{CE} = -30V, V_{BE} = 3V$	-	-	-50	nA
Emitter cut-off current	I_{EBO}	$V_{EB} = -5V, I_C = 0$	-	-	-50	nA
DC current gain	h_{FE}	$V_{CE} = -1V, I_C = -0.1mA$	60	-	-	
		$V_{CE} = -1V, I_C = -1mA$	80	-	-	
		$V_{CE} = -1V, I_C = -10mA$	100	-	300	
		$V_{CE} = -1V, I_C = -50mA$	60	-	-	
		$V_{CE} = -1V, I_C = -100mA$	30	-	-	
Collector-emitter saturation voltage	$V_{CE(sat)}$	$I_C = -10mA, I_B = -1mA$	-	-	-0.25	V
		$I_C = -50mA, I_B = -5mA$	-	-	-0.3	V
Base-emitter saturation voltage	$V_{BE(sat)}$	$I_C = -10mA, I_B = -1mA$	-	-	-0.85	V
		$I_C = -50mA, I_B = -5mA$	-	-	-0.95	V
Transition frequency	f_T	$V_{CE} = -20V, I_C = -10mA, f = 100MHz$	250	-	-	MHz
Delay time	t_d	$V_{CC} = -3V, V_{BC} = -0.5V, I_C = -10mA, I_{B1} = I_{B2} = -1mA$	-	-	35	ns
Rise time	t_r		-	-	35	ns
Storage time	t_s		-	-	225	ns
Fall time	t_f	$I_{B1} = -I_{B2} = -1mA$	-	-	75	ns

Typical Characteristics

Figure 1. Static Characteristic

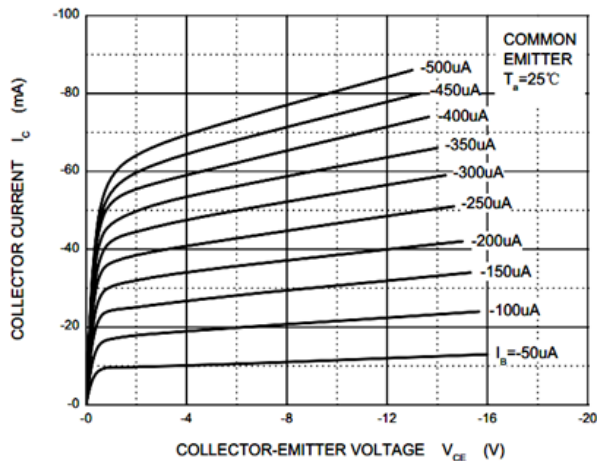

Figure 2. h_{FE} vs. I_c

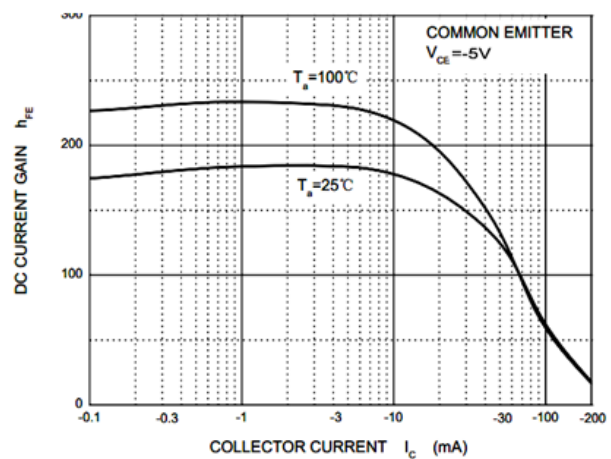

Figure 3. $V_{CE(sat)}$ vs. I_c

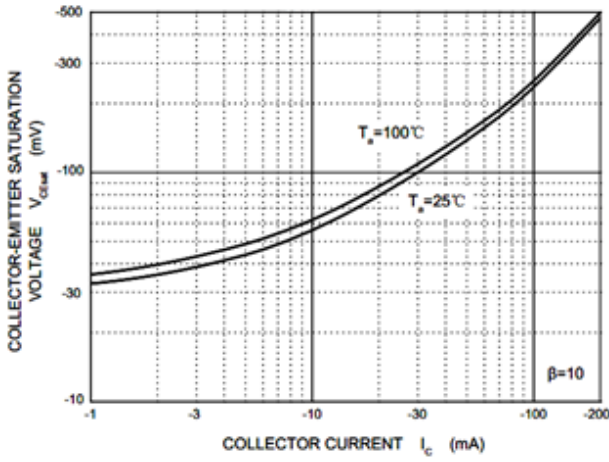

Figure 4. $V_{BE(sat)}$ vs. I_c

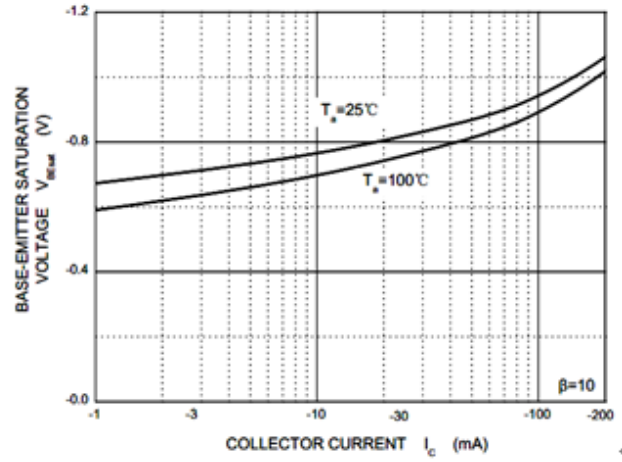

Figure 5. I_c vs. V_{BE}

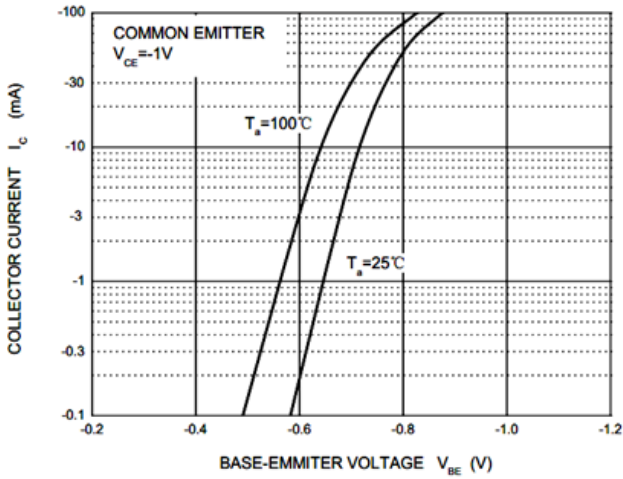

Figure 6. C_{ob} / C_{ib} vs. V_{CB} / V_{EB}

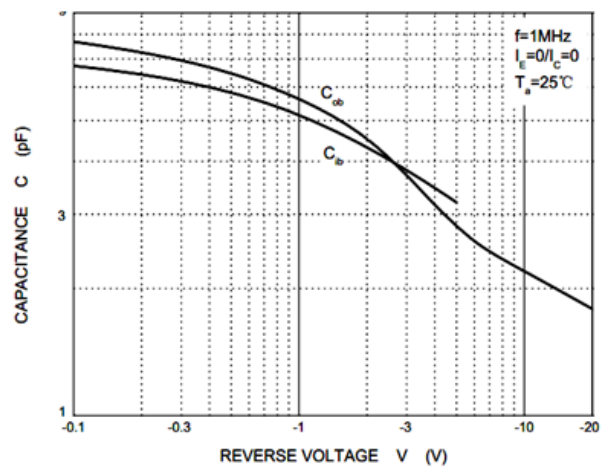
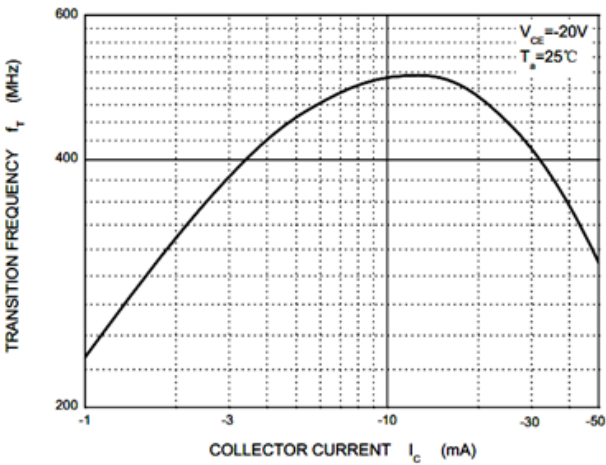
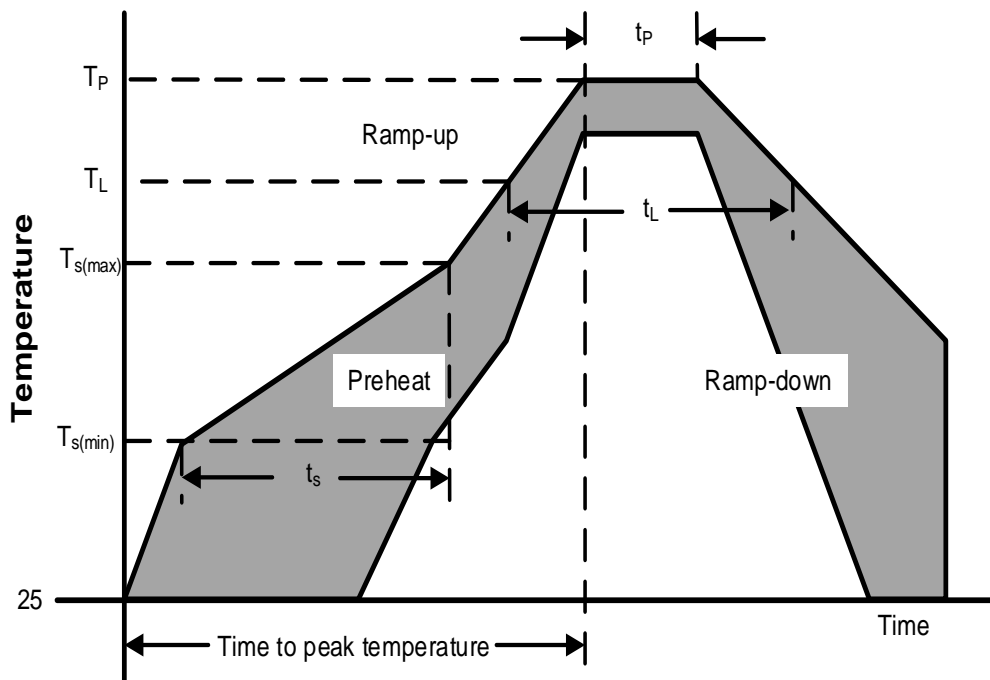

Figure 7. f_T vs. I_c



Soldering Parameters

Reflow Condition		Pb – Free assembly
Pre Heat	Temperature Min ($T_{s(min)}$)	150°C
	Temperature Max ($T_{s(max)}$)	200°C
	Time (min to max) (t_s)	60 – 190 secs
Average ramp up rate (Liquidus Temp) (T_L) to peak		5°C/second max
$T_{s(max)}$ to T_L — Ramp-up Rate		5°C/second max
Reflow	Temperature (T_L) (Liquidus)	217°C
	Temperature (t_L)	60 – 150 seconds
Peak Temperature (T_P)		260+0/-5 °C
Time within actual peak Temperature (t_p)		20 – 40 seconds
Ramp-down Rate		5°C/second max
Time 25°C to peak Temperature (T_P)		8 minutes Max.
Do not exceed		280°C



Tape And Reel Information

Reel Dimensions

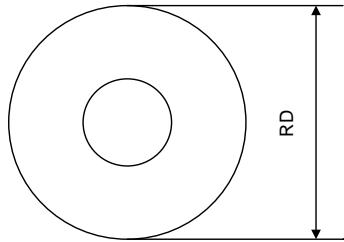

Tape Dimensions

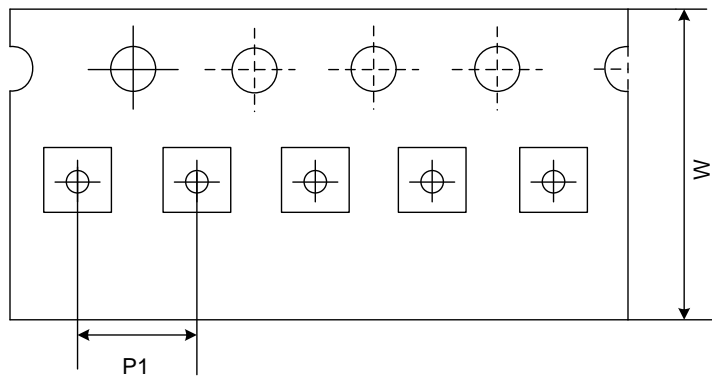

Quadrant Assignments For PIN1 Orientation In Tape

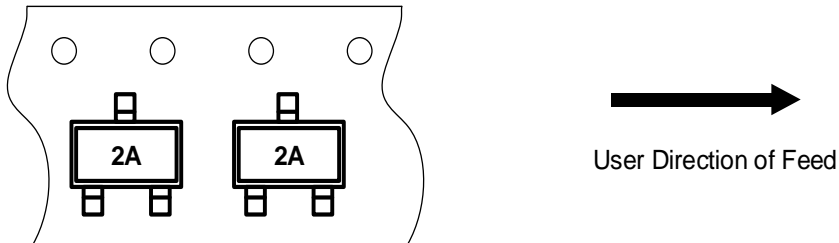

RD	Reel Dimensions	7 inch
W	Overall width of the carrier tape	8 mm
P1	Pitch between successive cavity centers	4mm

Outline Drawing – SOT-23

PACKAGE OUTLINE

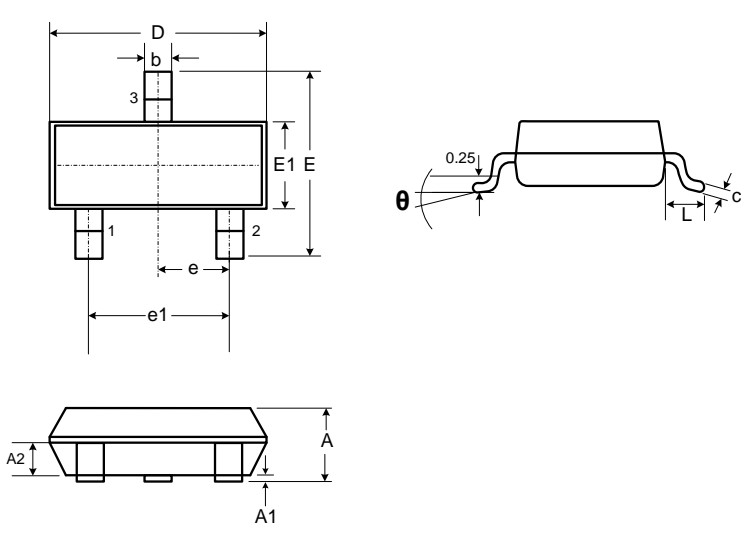

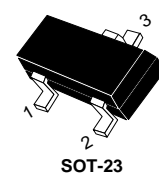

SOT-23

DIMENSIONS				
SYMBOL	MILLIMETER		INCHES	
	MIN	MAX	MIN	MAX
A	0.90	1.15	0.035	0.045
A1	0.00	0.10	0.000	0.004
A2	0.60	0.70	0.0236	0.0275
b	0.30	0.50	0.012	0.020
c	0.08	0.15	0.003	0.006
D	2.80	3.00	0.110	0.118
E	2.25	2.55	0.089	0.100
E1	1.20	1.40	0.047	0.055
e	0.95 BSC		0.0374 BSC	
e1	1.80	2.00	0.071	0.079
L	0.30	0.50	0.012	0.020
θ	0	8°	0	8°

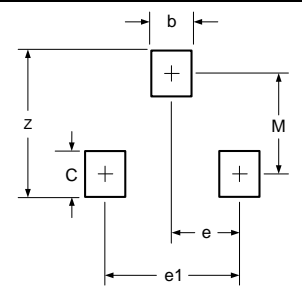

DIMENSIONS		
DIM	INCHES	MILLIMETERS
M	0.0795	2.02
C	0.0315	0.80
Z	0.111	2.82
e	0.037 BSC	0.95 BSC
e1	0.075 BSC	1.9 BSC
b	0.0315	0.80

Notes

1. Dimensioning and tolerances per ANSI Y14.5M, 1985.
2. Controlling Dimension: Inches
3. Pin 3 is the cathode (Unidirectional Only).
4. Dimensions are exclusive of mold flash and metal burrs.

Marking Codes

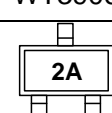
Part Number	WT3906
Marking Code	

Package Information

Qty: 3k/Reel

CONTACT INFORMATION

No.1001, Shiwan (7) Road, Pudong District, Shanghai, P.R.China.201207

Tel: 86-21-68969993 Fax: 86-21-50757680 Email: market@way-on.com

WAYON website: <http://www.way-on.com>

For additional information, please contact your local Sales Representative.

WAYON® is registered trademark of Wayon Corporation.

Specifications are subject to change without notice.
The device characteristics and parameters in this data sheet can and do vary in different applications and actual device performance may vary over time.
Users should verify actual device performance in their specific applications.