



5.0SMDJxx(C)A

Power Transient Voltage Suppressor

Features

- 5000 watts Peak Pulse Power (10/1000 μ s)
- Unidirectional and Bidirectional Protection
- Fast Response Time : Typically < 1ns
- Excellent Clamping Capability
- Built-in Strain relief
- Low inductance
- Low profile package
- IEC 61000-4-2 (ESD) \pm 30kV(air), \pm 30kV(contact)
- MSL: Level 1

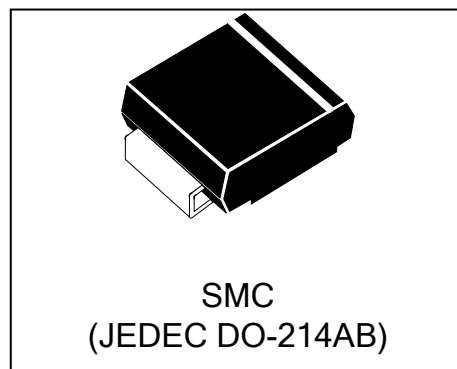

Mechanical Characteristics

- JEDEC DO-214AB package
- Molding compound flammability rating:
UL 94V-0
- Marking: Marking Code
- Packaging: Tape and Reel per EIA 481
- RoHS &UL497B Compliant

Applications

- I/O Interfaces
- Power lines
- Telecommunication
- Computers & Consumer Electronics
- Industrial Electronics

Absolute Maximum Rating			
Rating	Symbol	Value	Units
Peak Pulse Power ($t_p = 10/1000\mu s$) (see Note1,2& 3)	P _{PPM}	5000	Watts
Peak pulse current (10/1000 μ s) (see Note2&3)	I _{PPM}	See Electrical Characteristics	A
Peak Forward surge current (see Note4&5)	I _{FSM}	300	A
Power Dissipation on infinite heat sink T _L = 50 °C (Fig5)	P _D	6.5	W
Operating Junction Temperature range	T _J	-65 to + 150	°C
Storage Temperature range	T _{STG}	-65 to + 150	°C

Note1: Peak Pulse Power Rating as Pulse Width, per Fig1.

Note2: Peak Pulse Power or Current Derated above T_A=25°C Per Fig. 2 and Non-Repetitive Current Pulse, Per Fig.3.

Note3: Mounted on 5.0x5.0mm² copper pad to each terminal.

Note4: 8.3ms Single Half Sine Wave or Equivalent Square Wave.

Note5: Maximum Forward Surge Current only for Unidirectional Device per Fig6.

Electrical Characteristics

Part Number		Reverse Stand off Voltage V_{RWM} (Volts)	Breakdown Voltage		Test Current I_T (mA)	Maximum Clamping Voltage $V_C@I_{PP}$ (Volts)	Maximum Peak Pulse Current I_{PP} (Amps)	Maximum Reverse Leakage $I_R@V_{RWM}$ (μ A)
			$V_{BR}(\text{Volts})@I_T$					
UNI-POLAR	BI-POLAR		MIN	MAX				
5.0SMDJ12A	5.0SMDJ12CA	12	13.3	14.7	10	19.9	252.0	800
5.0SMDJ13A	5.0SMDJ13CA	13	14.4	15.9	10	21.5	233.0	500
5.0SMDJ14A	5.0SMDJ14CA	14	15.6	17.2	10	23.2	216.0	200
5.0SMDJ15A	5.0SMDJ15CA	15	16.7	18.5	1	24.4	205.0	100
5.0SMDJ16A	5.0SMDJ16CA	16	17.8	19.7	1	26.0	193.0	50
5.0SMDJ17A	5.0SMDJ17CA	17	18.9	20.9	1	27.6	181.0	20
5.0SMDJ18A	5.0SMDJ18CA	18	20.0	22.1	1	29.2	172.0	10
5.0SMDJ20A	5.0SMDJ20CA	20	22.2	24.5	1	32.4	155.0	5
5.0SMDJ22A	5.0SMDJ22CA	22	24.4	26.9	1	35.5	141.0	5
5.0SMDJ24A	5.0SMDJ24CA	24	26.7	29.5	1	38.9	129.0	5
5.0SMDJ26A	5.0SMDJ26CA	26	28.9	31.9	1	42.1	119.0	5
5.0SMDJ28A	5.0SMDJ28CA	28	31.1	34.4	1	45.4	110.0	5
5.0SMDJ30A	5.0SMDJ30CA	30	33.3	36.8	1	48.4	103.0	5
5.0SMDJ33A	5.0SMDJ33CA	33	36.7	40.6	1	53.3	93.9	5
5.0SMDJ36A	5.0SMDJ36CA	36	40.0	44.2	1	58.1	86.1	5
5.0SMDJ40A	5.0SMDJ40CA	40	44.4	49.1	1	64.5	77.6	5
5.0SMDJ43A	5.0SMDJ43CA	43	47.8	52.8	1	69.4	72.1	5
5.0SMDJ45A	5.0SMDJ45CA	45	50.0	55.3	1	72.7	68.8	5
5.0SMDJ48A	5.0SMDJ48CA	48	53.3	58.9	1	77.4	64.7	5
5.0SMDJ51A	5.0SMDJ51CA	51	56.7	62.7	1	82.4	60.7	5
5.0SMDJ54A	5.0SMDJ54CA	54	60.0	66.3	1	87.1	57.5	5
5.0SMDJ58A	5.0SMDJ58CA	58	64.4	71.2	1	93.6	53.5	5
5.0SMDJ60A	5.0SMDJ60CA	60	66.7	73.7	1	96.8	51.7	5
5.0SMDJ64A	5.0SMDJ64CA	64	71.1	78.6	1	103.0	48.6	5
5.0SMDJ70A	5.0SMDJ70CA	70	77.8	86.0	1	113.0	44.3	5
5.0SMDJ75A	5.0SMDJ75CA	75	83.3	92.1	1	121.0	41.4	5
5.0SMDJ78A	5.0SMDJ78CA	78	86.7	95.8	1	126.0	39.7	5
5.0SMDJ85A	5.0SMDJ85CA	85	94.4	104.0	1	137.0	36.5	5
5.0SMDJ90A	5.0SMDJ90CA	90	100.0	111.0	1	146.0	34.3	5
5.0SMDJ100A	5.0SMDJ100CA	100	111.0	123.0	1	162.0	30.9	5
5.0SMDJ110A	5.0SMDJ110CA	110	122.0	135.0	1	177.0	28.3	5
5.0SMDJ120A	5.0SMDJ120CA	120	133.0	147.0	1	193.0	26.0	5
5.0SMDJ130A	5.0SMDJ130CA	130	144.0	159.0	1	209.0	24.0	5
5.0SMDJ150A	5.0SMDJ150CA	150	167.0	185.0	1	243.0	20.6	5
5.0SMDJ160A	5.0SMDJ160CA	160	178.0	197.0	1	259.0	19.3	5
5.0SMDJ170A	5.0SMDJ170CA	170	189.0	209.0	1	275.0	18.2	5

Typical Characteristics

Figure 1: Peak Pulse Power Rating Curve

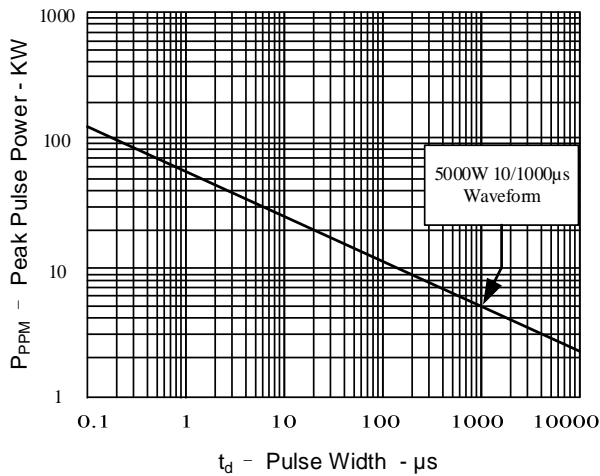

Figure 2: Pulse Derating Curve

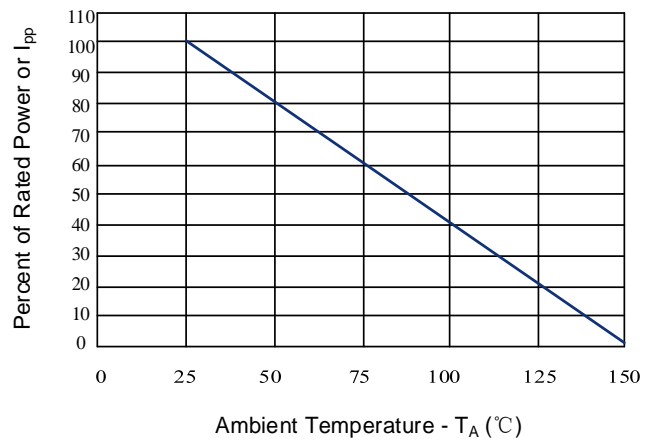

Figure 3: Pulse Waveform

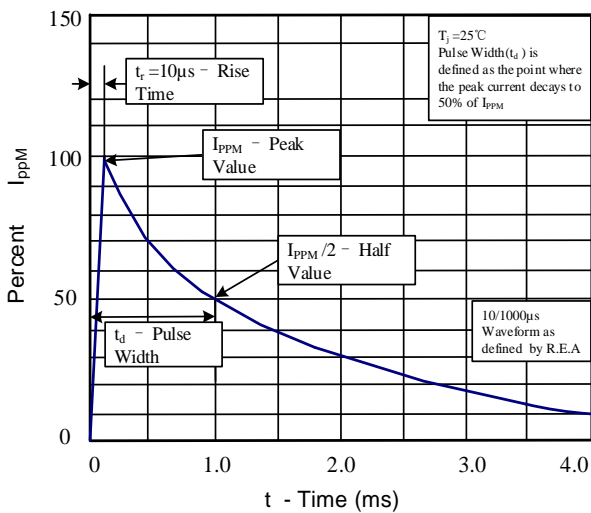

Figure 4: Typical Junction Capacitance

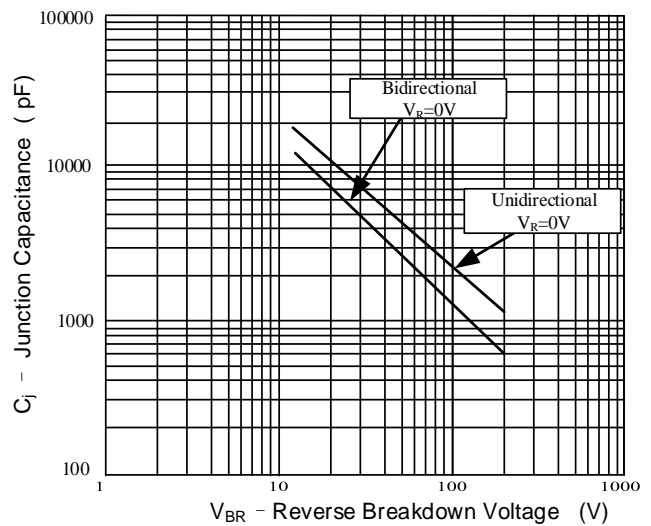

Figure 5: Steady State Power Dissipation Derating Curve

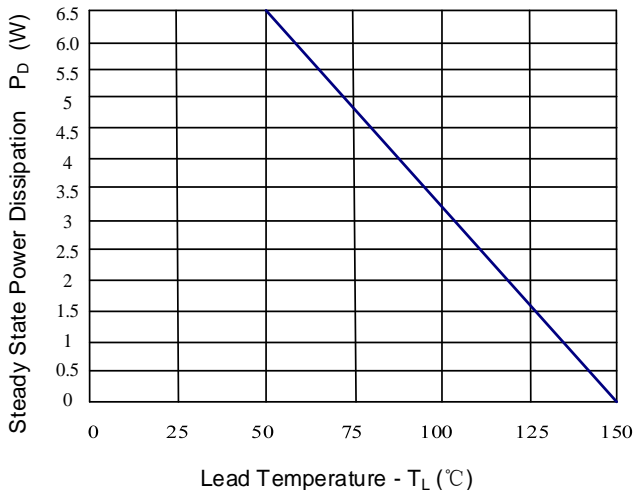
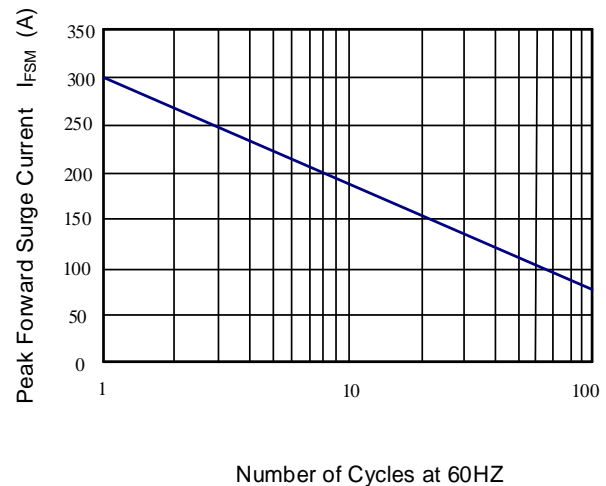

Figure 6: Maximum Non-Repetitive Forward Surge Current Only Unidirectional



Note: The above typical parameters or typical characteristics are only indicative and do not make specific guarantees. If detailed values are required, additional communication and provision are required.

Recommended Soldering Parameters

Reflow Condition		
Pre-Heat	Temperature min ($T_{s(min)}$)	150°C
	Temperature max ($T_{s(max)}$)	200°C
	Time (min to max) (t_s)	60-190 s
Average ramp up rate (Liquidus Temp) (T_L) to peak		3°C/s max
Ts(max) to TL - Ramp-up Rate		3°C/s max
Reflow	Temperature (T_L) (Liquidus)	217°C
	Temperature (t_L)	60-150 s
Peak Temperature (T_P)		260 ^{+0/-5} °C
Time within actual peak Temperature (t_p)		20-40 s
Ramp-down Rate		5°C/s max
Time 25°C to peak Temperature (T_P)		8 minutes max
Do not exceed		260°C

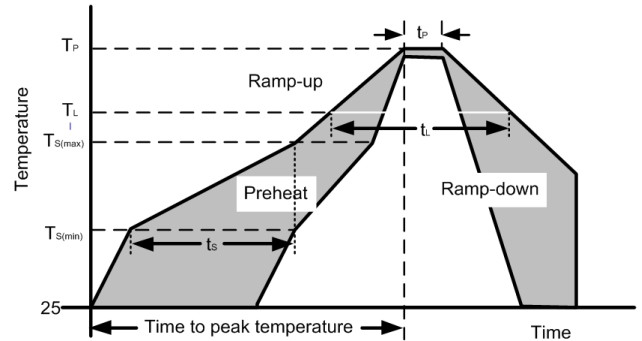

Outline Drawing – SMC(DO-214AB)

Ref. (mm)	Millimeters	
	Min.	Max.
A	2.06	2.70
A1	-	0.30
B	2.90	3.20
E	6.60	7.40
E1	7.75	8.13
D	5.59	6.22
L	0.76	1.52

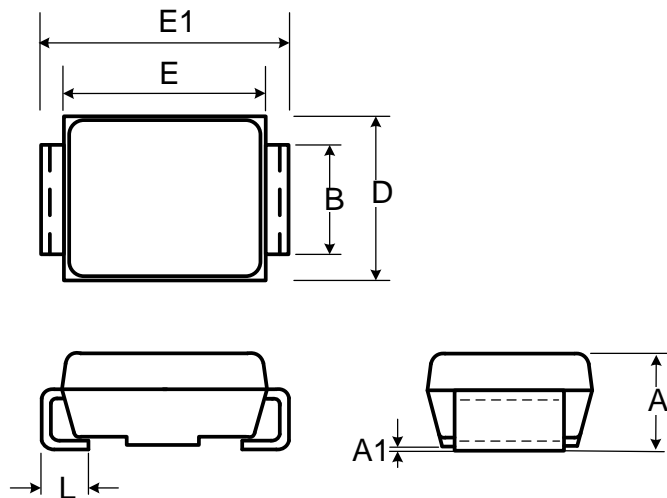

Recommended Solder Pad Layout

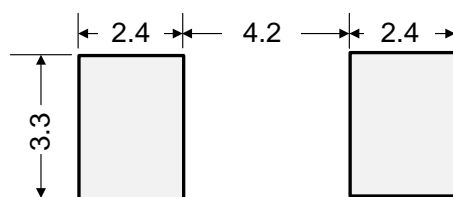

Dimensions in mm

Part Numbering System

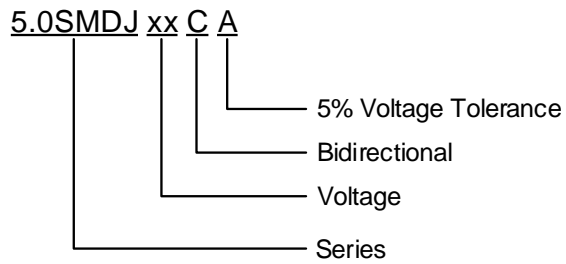

Part Marking System

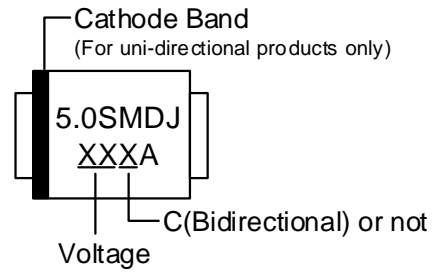

Package Information

Package Type	Description	Quantity (pcs)	Standard
SMC(DO-214AB)	Tape & Reel -16mm/13" tape	3000	EIA-481-D

Tape and Reel Information

Reel Dimensions

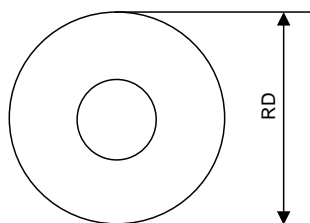

Tape Dimensions

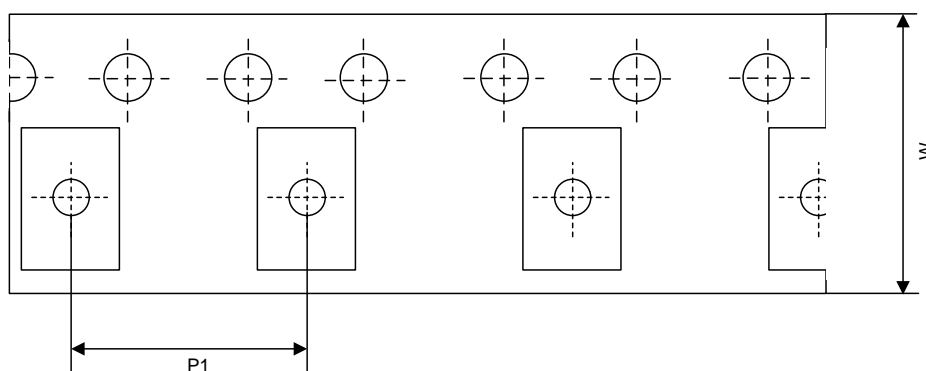

Quadrant Assignments for PIN1 Orientation in tape

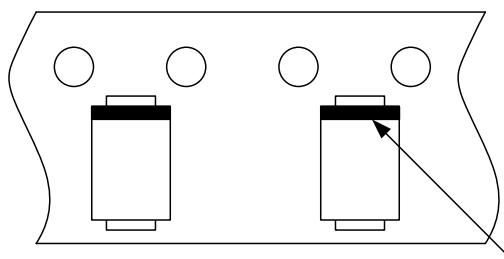

→
User Direction of Feed

Uni-directional products only

RD	Reel Dimensions	13 inch
W	Overall width of the carrier tape	16 mm
P1	Pitch between successive cavity centers	8 mm

Contact Information

No.1001, Shiwan(7) Road, Pudong District, Shanghai, P.R.China.201207

Tel: 86-21-50310888 Fax: 86-21-50757680 Email: market@way-on.com

WAYON website: <http://www.way-on.com>

For additional information, please contact your local Sales Representative.

WAYON® is registered trademarks of Wayon Corporation.

Product Specification Statement

The product specification aims to provide users with a reference regarding various product parameters, performance, and usage. It presents certain aspects of the product's performance in graphical form and is intended solely for users to select product and make product comparisons, enabling users to better understand and evaluate the characteristics and advantages of the product. It does not constitute any commitment, warranty, or guarantee.

The product parameters described in the product specification are numerical values, characteristics, and functions obtained through actual testing or theoretical calculations of the product in an independent or ideal state. Due to the complexity of product applications and variations in test conditions and equipment, there may be slight fluctuations in parameter test values. WAYON shall not guarantee that the actual performance of the product when installed in the customer's system or equipment will be entirely consistent with the product specification, especially concerning dynamic parameters. It is recommended that users consult with professionals for product selection and system design. Users should also thoroughly validate and assess whether the actual parameters and performance when installed in their respective systems or equipment meet their requirements or expectations. Additionally, users should exercise caution in verifying product compatibility issues, and WAYON assumes no responsibility for the application of the product.

WAYON strives to provide accurate and up-to-date information to the best of our ability. However, due to technical, human, or other reasons, WAYON cannot guarantee that the information provided in the product specification is entirely accurate and error-free. WAYON shall not be held responsible for any losses or damages resulting from the use or reliance on any information in these product specifications. WAYON reserves the right to revise or update the product specification and the products at any time without prior notice, and the user's continued use of the product specification is considered an acceptance of these revisions and updates. Prior to purchasing and using the product, users should verify the above information with WAYON to ensure that the product specification is the most current, effective, and complete. If users are particularly concerned about product parameters, please consult WAYON in detail or request relevant product test reports. Any data not explicitly mentioned in the product specification shall be subject to separate agreement.

Users are advised to pay attention to the parameter limit values specified in the product specification and maintain a certain margin in design or application to ensure that the product does not exceed the parameter limit values defined in the product specification. This precaution should be taken to avoid exceeding one or more of the limit values, which may result in permanent irreversible damage to the product, ultimately affecting the quality and reliability of the system or equipment.

The design of the product is intended to meet civilian needs and is not guaranteed for use in harsh environments or precision equipment. It is not recommended for use in systems or equipment such as medical devices, aircraft, nuclear power, and similar systems, where failures in these systems or equipment could reasonably be expected to result in personal injury. WAYON shall assume no responsibility for any consequences resulting from such usage.

Users should also comply with relevant laws, regulations, policies, and standards when using the product specification. Users are responsible for the risks and liabilities arising from the use of the product specification and must ensure that it is not used for illegal purposes. Additionally, users should respect the intellectual property rights related to the product specification and refrain from infringing upon any third-party legal rights. WAYON shall assume no responsibility for any disputes or controversies arising from the above-mentioned issues in any form.