

Features

- Ideally Suited for Automatic Insertion
- For Switching and AF Amplifier Applications

Mechanical Characteristics

- SOT-323 Package
- Marking : Making Code
- RoHS Compliant

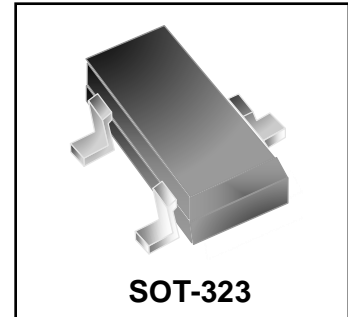

Schematic & PIN Configuration

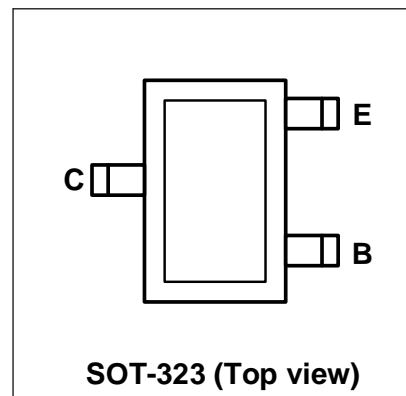
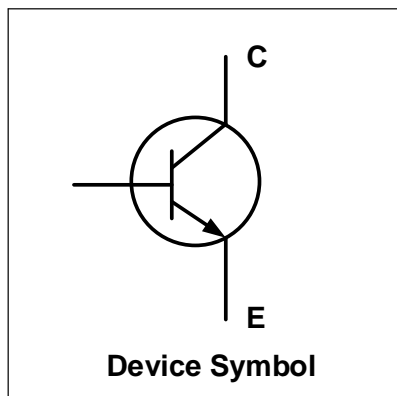

Absolute Maximum Rating

Parameter	Symbol	Value	Unit
Collector Base Voltage	V_{CBO}	50	V
Collector Emitter Voltage	V_{CEO}	45	V
Emitter Base Voltage	V_{EBO}	6	V
Collector Current	I_C	0.1	A
Peak Collector Current	I_{CM}	0.2	A
Collector Power Dissipation	P_C	200	mW
Junction Temperature	T_j	150	°C
Storage Temperature	T_{stg}	-55 ~ +150	°C

Electrical Characteristics ($T_{amb}=25^{\circ}C$ unless otherwise noted)

Parameter	Symbol	Test Conditions	Min.	Typ.	Max.	Unit
Collector-Base Breakdown Voltage	$V_{(BR)CBO}$	$I_C = 10\mu A, I_E = 0$	50	-	-	V
Collector-Emitter Breakdown Voltage	$V_{(BR)CEO}$	$I_C = 10mA, I_B = 0$	45	-	-	V
Emitter-Base Breakdown Voltage	$V_{(BR)EBO}$	$I_E = 1\mu A, I_C = 0$	6	-	-	V
Collector Cut-Off Current	I_{CBO}	$V_{CB} = 30V, I_E = 0$	-	-	15	nA
Emitter Cut-Off Current	I_{EBO}	$V_{EB} = 5V, I_C = 0$	-	-	100	nA
DC Current Gain	h_{FE}	$V_{CE} = 5V, I_C = 2mA$	200	-	450	-
Collector-Emitter Saturation Voltage	$V_{CE(sat)}$	$I_C = 10mA, I_B = 0.5mA$	-	-	0.25	V
		$I_C = 100mA, I_B = 5mA$	-	-	0.6	
Base-Emitter Voltage	V_{BE}	$V_{CE}=5V, I_C = 2mA$	0.58	-	0.7	V
		$V_{CE}=5V, I_C = 10mA$	-	-	0.77	
Transition Frequency	f_T	$V_{CE}=5V, I_C=10mA, f=100MHz$	100	-	-	MHz
Collector Output Capacitance	C_{ob}	$V_{CB} = 10V, I_E = 0, f = 1MHz$	-	-	4.5	pF

Typical Characteristics

Figure 1. Static Characteristics

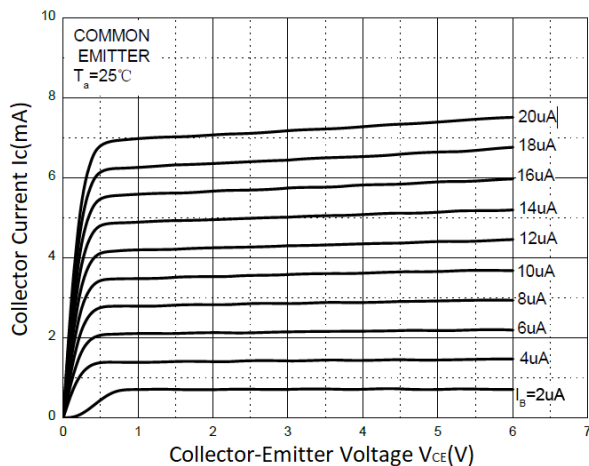

Figure 2. h_{FE} vs. I_C

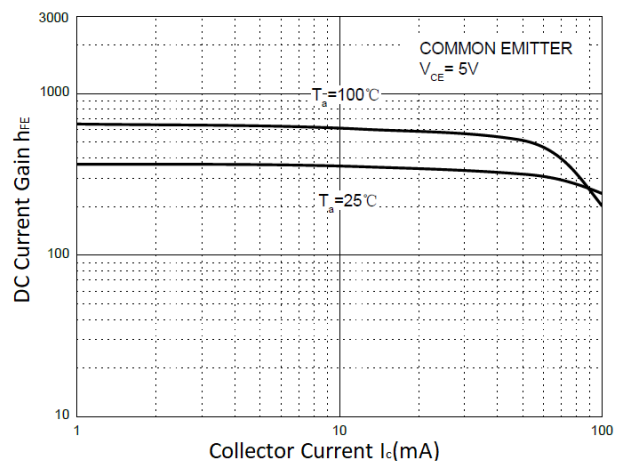

Figure 3. $V_{BE(sat)}$ vs. I_c

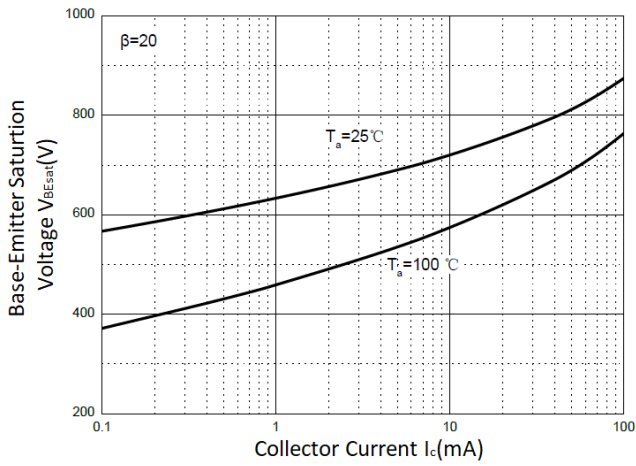

Figure 4. $V_{CE(sat)}$ vs. I_c

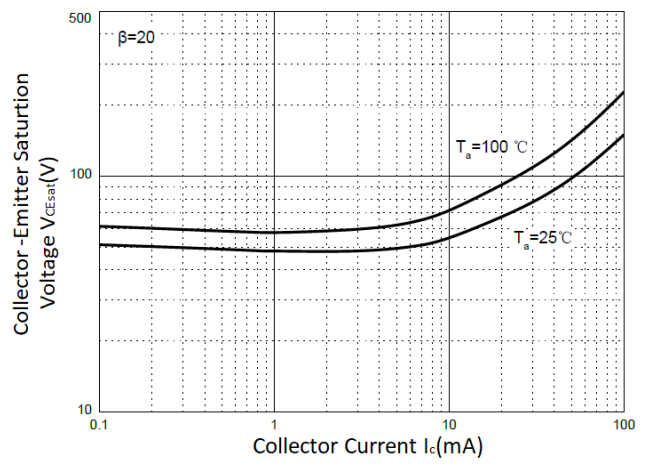

Figure 5. I_c vs. V_{BE}

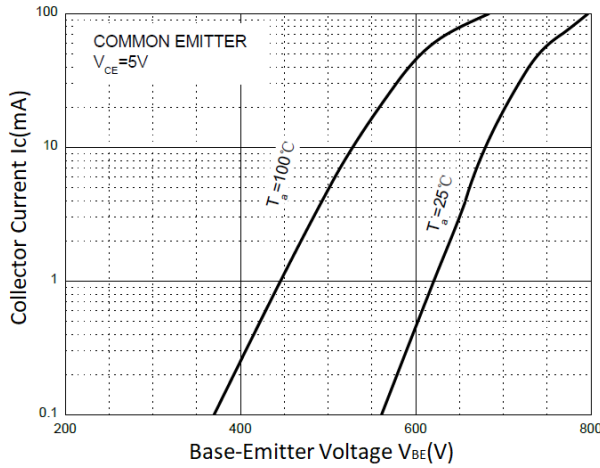

Figure 6. f_T vs. I_c

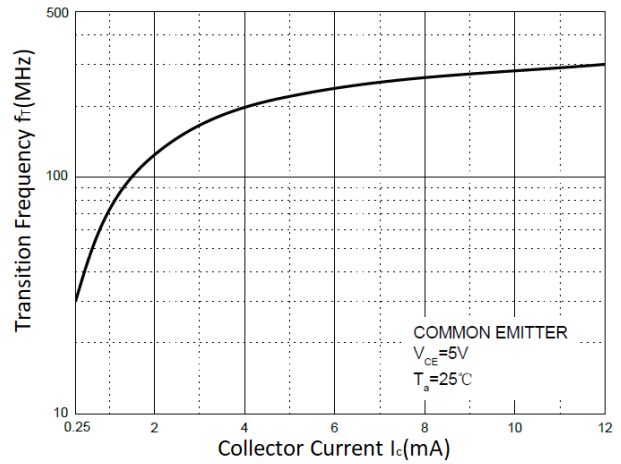

Figure 7. C_{ob} / C_{ib} vs. V_{CB} / V_{EB}

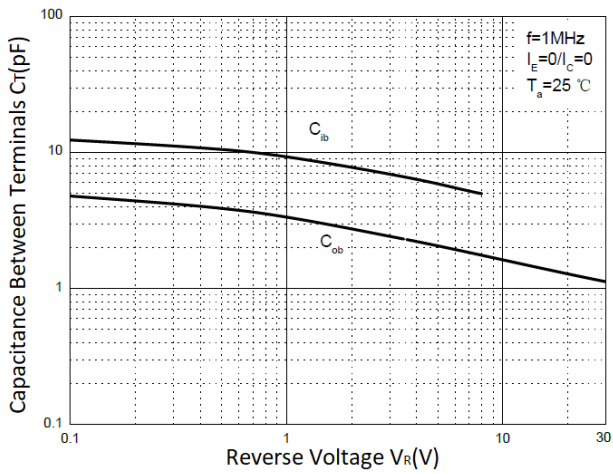
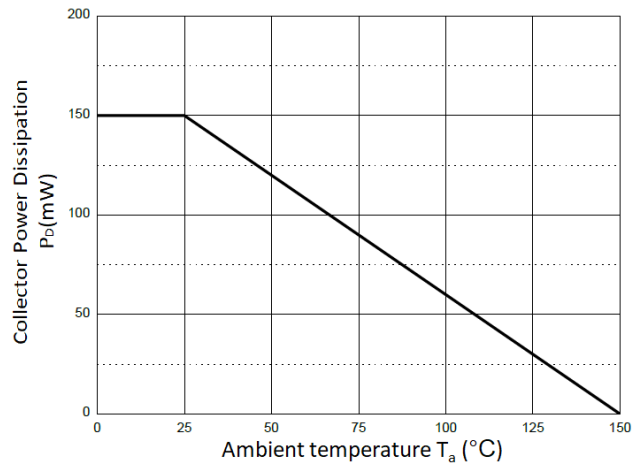

Figure 8. P_c vs. T_a



Outline Drawing – SOT-323

PACKAGE OUTLINE

SOT-323

DIMENSIONS				
SYMBOL	MILLIMETER		INCHES	
	MIN.	MAX.	MIN.	MAX.
A	0.900	1.100	0.035	0.043
A1	0.000	0.100	0.000	0.004
D	2.000	2.200	0.079	0.087
b	0.300	0.500	0.012	0.020
c	0.100	0.150	0.004	0.006
E	2.150	2.450	0.085	0.096
E1	1.150	1.350	0.045	0.053
e	0.650TYP		0.026TYP	
L	0.525 REF		0.021 REF	
θ	0	8°	0	8°

DIMENSIONS		
DIM	INCHES	MILLIMETERS
M	0.076	1.90
C	0.036	0.9
Z	0.108	2.7
e	0.026	0.65
e1	0.052	1.30
b	0.028	0.7

Notes

1. Dimensioning and tolerances per ANSI Y14.5M, 1985.
2. Controlling Dimension: Inches
3. Pin 3 is the cathode (Unidirectional Only).
4. Dimensions are exclusive of mold flash and metal burrs.

Marking Codes

Part Number	WT847BW
Marking Code	

Package Information

Qty: 3k/Reel

CONTACT INFORMATION

No.1001, Shiwan (7) Road, Pudong District, Shanghai, P.R.China.201207
 Tel: 86-21-68969993 Fax: 86-21-50757680 Email: market@way-on.com
 WAYON website: <http://www.way-on.com>

For additional information, please contact your local Sales Representative.

WAYON® is registered trademark of Wayon Corporation.

Specifications are subject to change without notice.
 The device characteristics and parameters in this data sheet can and do vary in different applications and actual device performance may vary over time.
 Users should verify actual device performance in their specific applications.