

Features

- 500 Watts Peak Pulse Power per Line ($t_p = 8/20\mu s$)
- Bidirectional Configuration
- Protects One Power or I/O Port
- Low Clamping Voltages
- Ultra Low Capacitance: 1.0 pF Typical

IEC COMPATIBILITY (EN61000-4)

- IEC 61000-4-2 (ESD) $\pm 30kV$ (air), $\pm 30kV$ (contact)
- IEC 61000-4-4 (EFT) 40A (5/50ns)
- IEC 61000-4-5 (Lightning) 20A (8/20 μs)

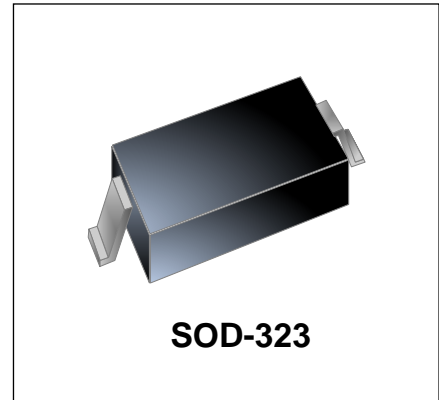

Mechanical Characteristics

- SOD-323 package
- Marking: Marking Code
- Packaging: Tape and Reel
- RoHS Compliant & HF
- Device meets MSL3 requirement

Applications

- Ethernet - 10/100/1000 Base T
- Cellular Phones
- Handheld - Wireless Systems
- Personal Digital Assistant (PDA)
- USB Interface

PIN Configuration

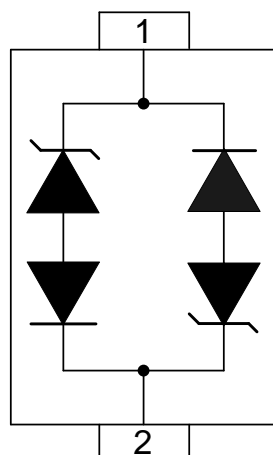

BIDIRECTIONAL

| Absolute Maximum Rating | | | |
|--|-----------|--------------|-------|
| Rating | Symbol | Value | Units |
| Peak Pulse Power ($t_p = 8/20\mu s$) | P_{PP} | 500 | W |
| Peak Pulse Current ($t_p = 8/20\mu s$) | I_{pp} | 20 | A |
| Operating Temperature | T_J | -55 to + 125 | °C |
| Storage Temperature | T_{STG} | -55 to +150 | °C |

Electrical Parameters

| Symbol | Parameter |
|-----------|-------------------------------------|
| I_{PP} | Reverse Peak Pulse Current |
| V_C | Clamping Voltage @ I_{PP} |
| V_{RWM} | Reverse Stand-Off Voltage |
| I_R | Reverse Leakage Current @ V_{RWM} |
| V_{BR} | Breakdown Voltage @ I_T |
| I_T | Test Current |

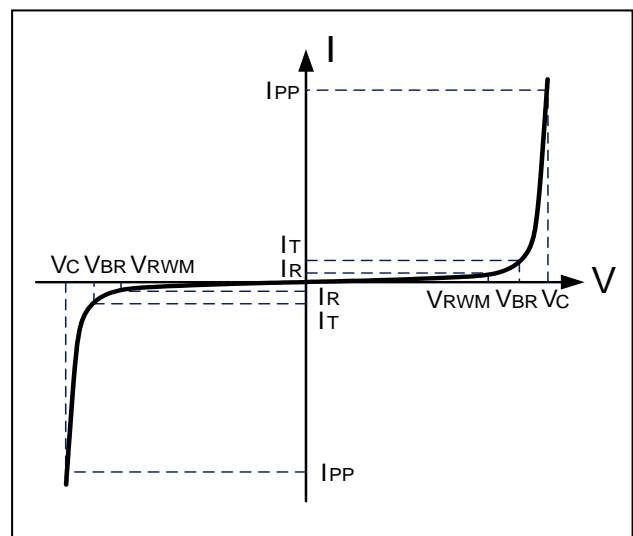

Electrical characteristics(T=25°C unless otherwise noted)

| WS08DLC-B | | | | | | |
|-----------------------------------|-----------|-------------------------------------|---------|---------|---------|----------|
| Parameter | Symbol | Conditions | Minimum | Typical | Maximum | Units |
| Reverse Stand-Off Voltage | V_{RWM} | | | | 8 | V |
| Reverse Breakdown Voltage | V_{BR} | $I_T=1mA$ | 8.5 | | 12 | V |
| Reverse Leakage Current | I_R | $V_{RWM}=8V$ | | | 500 | nA |
| Clamping Voltage | V_C | $I_{PP}=20A, t_p=8/20\mu s$ | | 21 | 25 | V |
| Dynamic Resistance ^{1,2} | R_{DYN} | $TLP=0.2/100ns$ | | 0.33 | | Ω |
| ESD Clamping Voltage ¹ | V_C | $I_{PP} = 4A$ $t_p = 0.2/100ns$ | | 12 | | V |
| ESD Clamping Voltage ¹ | V_C | $I_{PP} = 16A$ $t_p = 0.2/100ns$ | | 16 | | V |
| Junction Capacitance | C_j | $V_R = 0V, f = 1MHz$ | | 1 | 1.5 | pF |

Note: 1、 TLP Setting : $t_p=100ns, t_r=0.2ns, I_{TLP}$ and V_{TLP} sample window: $t_1=70ns$ to $t_2=90ns$.

2、 Dynamic resistance calculated from $I_{PP}=4A$ to $I_{PP}=16A$ using “Best Fit”

Figure 1: Peak Pulse Power Vs Pulse Time

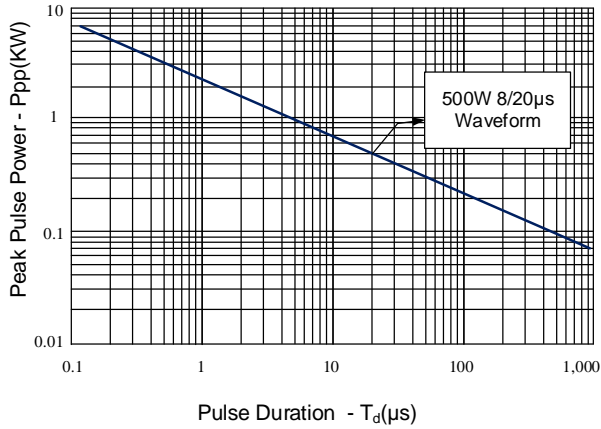

Figure 2: Power Derating Curve

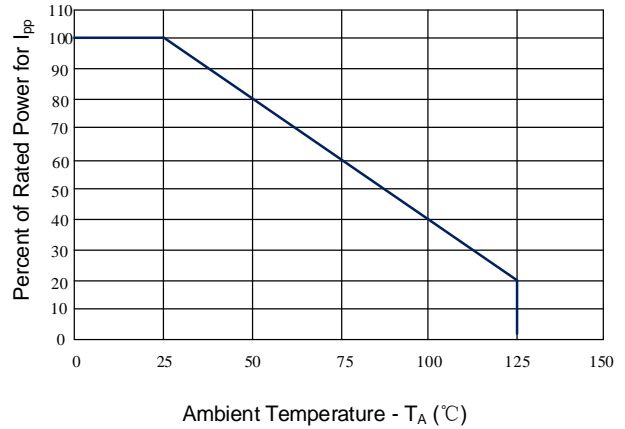

Figure 3: Clamping Voltage vs. Peak Pulse Current

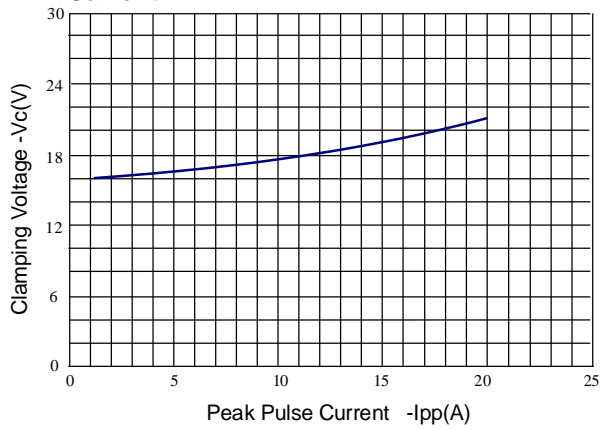

Figure 4: Normalized Junction Capacitance vs. Reverse Voltage

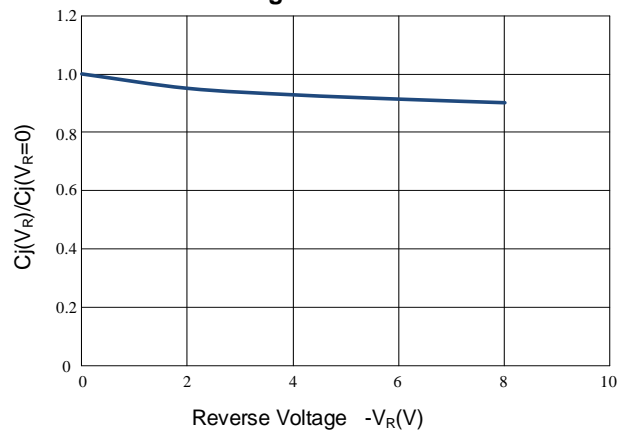

Figure 5: TLP Positive I-V Curve

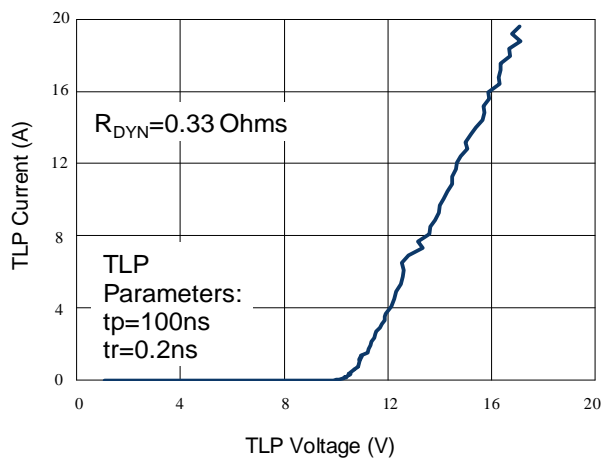
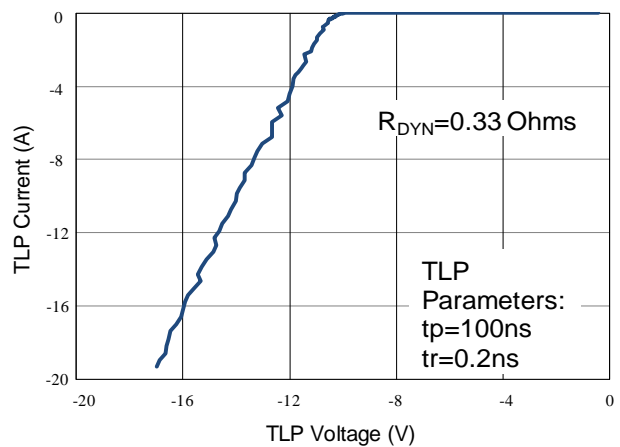
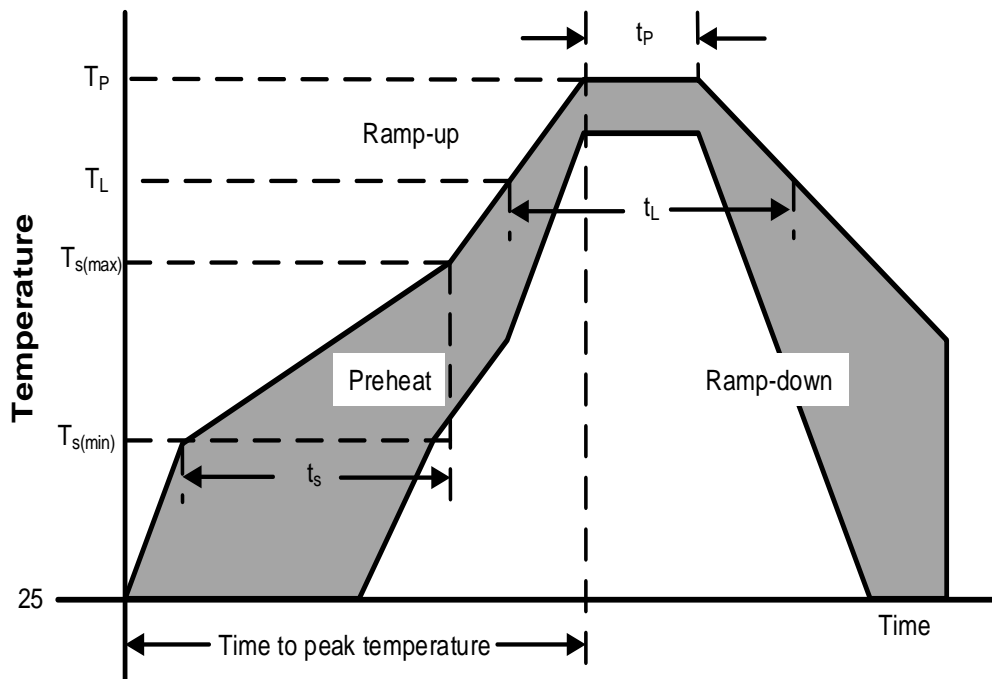

Figure 6: TLP Negative I-V Curve



| Reflow Condition | | Pb – Free assembly |
|--|----------------------------------|--------------------|
| Pre Heat | Temperature Min ($T_{s(min)}$) | 150°C |
| | Temperature Max ($T_{s(max)}$) | 200°C |
| | Time (min to max) (t_s) | 60 – 190 secs |
| Average ramp up rate (Liquidus Temp) (T_L) to peak | | 5°C/second max |
| $T_{s(max)}$ to T_L —Ramp-up Rate | | 5°C/second max |
| Reflow | Temperature (T_L) (Liquidus) | 217°C |
| | Temperature (t_L) | 60 – 150 seconds |
| Peak Temperature (T_P) | | 260+0/-5 °C |
| Time within actual peak Temperature (t_p) | | 20 – 40 seconds |
| Ramp-down Rate | | 5°C/second max |
| Time 25°C to peak Temperature (T_P) | | 8 minutes Max. |
| Do not exceed | | 280°C |



Reel Dimensions

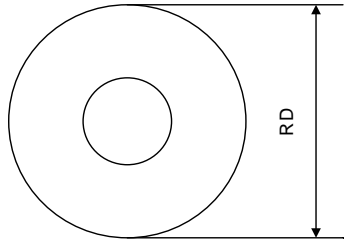

Tape Dimensions

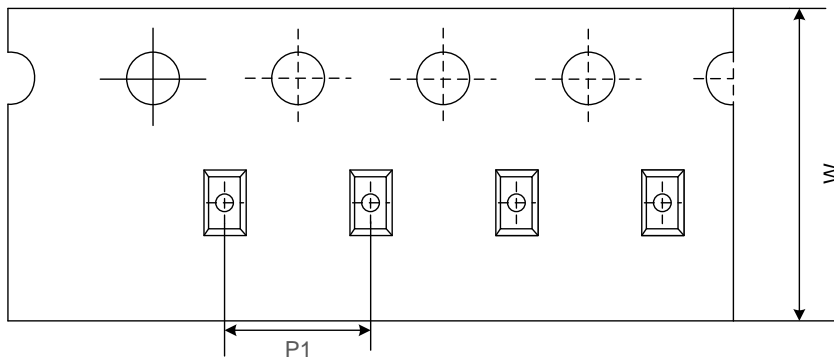

Quadrant Assignments For PIN1 Orientation In Tape

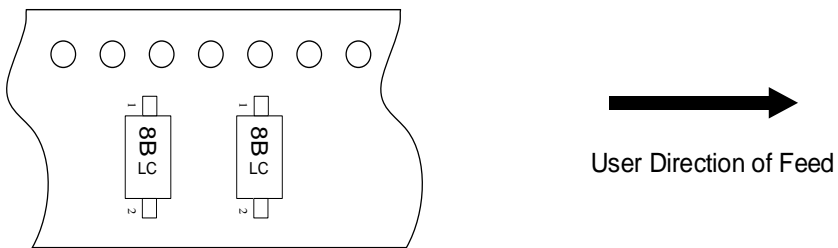

| | | |
|----|---|--------|
| RD | Reel Dimensions | 7 inch |
| W | Overall width of the carrier tape | 8 mm |
| P1 | Pitch between successive cavity centers | 4mm |

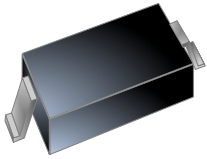
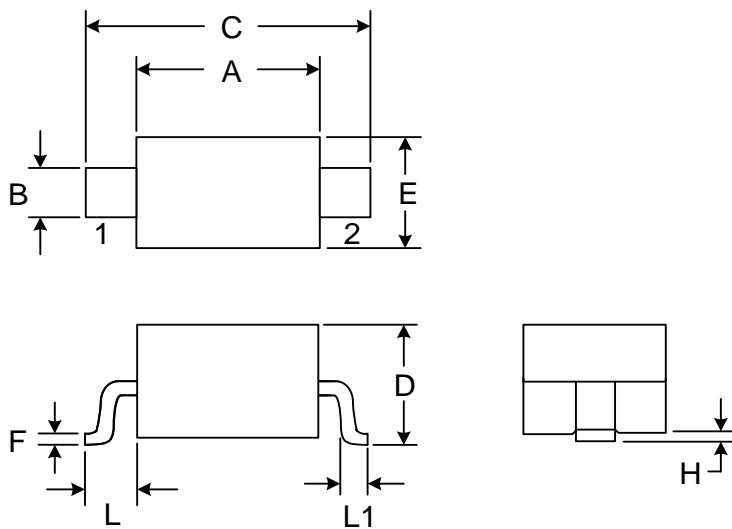
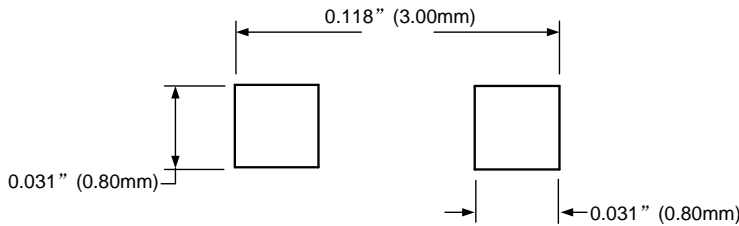
| PACKAGE OUTLINE | |  SOD-323 | | | |
|--|-------------|--|----------|-------|--|
|  | | DIMENSIONS | | | |
| SYMBOL | MILLIMETERS | | INCHES | | |
| | MIN | MAX | MIN | MAX | |
| A | 1.52 | 1.80 | 0.060 | 0.071 | |
| B | 0.25 | 0.40 | 0.010 | 0.016 | |
| C | 2.46 | 2.71 | 0.097 | 0.107 | |
| D | 0.80 | 1.16 | 0.031 | 0.046 | |
| E | 1.11 | 1.40 | 0.044 | 0.055 | |
| F | 0.08 | 0.20 | 0.003 | 0.008 | |
| L | 0.475 REF | | 0.019REF | | |
| L1 | 0.25 | 0.40 | 0.010 | 0.016 | |
| H | 0.00 | 0.10 | 0.000 | 0.004 | |
| MOUNTING PAD  | | Notes: Controlling Dimension: Millimeter. | | | |

Marking Codes

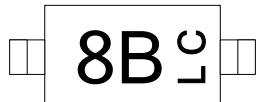
| Part Number | Marking Code |
|-------------|---|
| WS08DLC-B |  |

Package Information

Qty: 3k/Reel

CONTACT INFORMATION

No.1001, Shiwan (7) Road, Pudong District, Shanghai, P.R.China.201207
 Tel: 86-21-68969993 Fax: 86-21-50757680 Email: market@way-on.com
 WAYON website: <http://www.way-on.com>

For additional information, please contact your local Sales Representative.

WAYON ® is registered trademark of WAYON Corporation.

*Specifications are subject to change without notice.
 The device characteristics and parameters in this data sheet can and do vary in different applications and actual device performance may vary over time.
 Users should verify actual device performance in their specific applications.*